

Department of Physics  
New York University

MODERN PHYSICS I.  
(V85.0103)

MILLIKAN OIL DROP EXPERIMENT

M.1. Introduction

Robert Millikan reported in 1910 a method for measuring the charge  $e$  of a single electron by monitoring the motion of a droplet of oil suspended in a chamber and subjected to a vertical electrical force. Modern versions of this experiment have been applied to search for particles with  $(1/3)e$  or  $(2/3)e$  charge, corresponding to the charge of a quark. Some of these involve monitoring the motion of a tiny superconducting sphere subjected to magnetic and electric levitating fields. In this experiment you will carry out the original experiment of Millikan. At the end of the description of the experiment is a section on Historical Notes that gives a flavor of Millikan's original work.

M.2. Theory

We consider a cloud chamber of the kind developed by H.S. Wilson where an ionizing source can charge the droplets. The terminal velocity  $v_T$  of a droplet of mass  $m$  is dictated by the balance of gravitational and viscous forces (Fig. M.1):

$$\checkmark \quad mg = kv_T \quad (M.1)$$

Now if an electric field  $E$  is applied in the vertical direction (Fig. M.2) and the droplet has charge  $e_n$ , when the field strength is sufficient to cause the droplet to rise the balance of forces becomes:

$$Ee_n = mg + kv_T \quad (M.2)$$

In both cases there is a small buoyant force exerted by the air on the droplet. Since the density of air, however, is only about  $10^{-3}$  of that of oil this force may be neglected.

Eliminating  $k$  from Eqs. M.1 and M.2 and solving for  $e_n$  yields:

$$e_n = mg(v_f + v_T)/Ev_f \quad (M.3)$$

To eliminate  $m$  from Eq. M.3 we can use the expression for the volume of a sphere of radius  $a$ :

$$m = (4/3)\pi r^3 \sigma \quad (M.4)$$

where  $\sigma$  is the density of the oil. Since the radius cannot be determined accurately by direct observation, we can resort to Stokes' Law relating the radius of a spherical body to its terminal velocity of fall in a viscous medium of coefficient of viscosity  $n$ :

$$r = (9nv_f/2g\sigma)^{1/2} \quad (M.5)$$

Substituting M.4 and M.5 into M.3 gives:

$$e_n = (4\pi/3)[(9n/2)^3/g\sigma]^{1/2} \times [(v_f+v_r)v_f^{1/2}/E] \quad (M.6)$$

Stokes' Law however becomes inaccurate when the velocity of fall of the droplets is less than about 0.1 cm/sec. (Droplets having this and smaller velocities have radii on the order of 2  $\mu$ m, which is comparable to the mean free path of air molecules, a condition that violates one of the assumptions made in deriving Stokes' law.) Since the velocities of the droplets used in this experiment will be in the range of 0.01 to 0.001 cm/sec, a correction factor must multiply the right side of Eq. M.6 for  $e_n$  (see R.A. Millikan, The Electron, University of Chicago Press, Chapter 5). This factor is:

$$[1 + (b/pa)]^{-3/2} \quad (M.7)$$

where  $b$  is a constant,  $p$  is the atmospheric pressure, and  $a$  is the radius of the droplet as calculated by the uncorrected form of Stokes' Law, Eq. M.5.

The electric field is given by  $E = V_p/d$ , where  $V_p$  is the voltage between the parallel plates, which are separated by a distance  $d$  (See Fig. M.3). Substituting this and Eq. M.7 into Eq. M.6, on rearranging we obtain:

$$e_n = ([4\pi d/3][(9n/2)^3/g\sigma]^{1/2})\{[1+(b/pa)]^{3/2}\}((v_f+v_r)v_f^{1/2}/V_p) \quad (M.8)$$

If all quantities are evaluated in S.I. units (kg-m-sec), except for barometric pressure which should be in meters of mercury, then the charge is in coulombs. The terms in the first set of brackets need only be determined once for any particular apparatus. The second term is determined for each droplet, while the term in the third set of brackets is calculated for each change of charge which the drop experiences.

The definitions of the symbols used, together with their proper units for use in Eq. M.8 are:

- $e_n$  - Charge carried by the droplet in coulombs
- $d$  - Separation of the plates producing the electric field in meters
- $\sigma$  - Density of the oil in  $\text{kg/m}^3$
- $g$  - Acceleration of gravity in  $\text{m/sec}^2$
- $n$  - Viscosity of air (newton-sec/ $\text{m}^2$ )
- $b$  - Constant, equal to  $6.17 \times 10^{-8} \text{ m}^2$
- $p$  - Barometric pressure in meters of mercury

- a - Radius of the drop in meters, as calculated by Eq. M.5
- $v_f$  - Velocity of fall in m/sec
- $v_r$  - Velocity of rise in m/sec
- V - Voltage across the plate in volts

Note that the accepted value for e is  $1.602 \times 10^{-19}$  coulomb.

Includes  
Teacher's Notes  
and  
Typical  
Experiment Results



**Instruction Manual and  
Experiment Guide for the  
PASCO scientific  
Model AP-8210**

# MILLIKAN OIL DROP APPARATUS

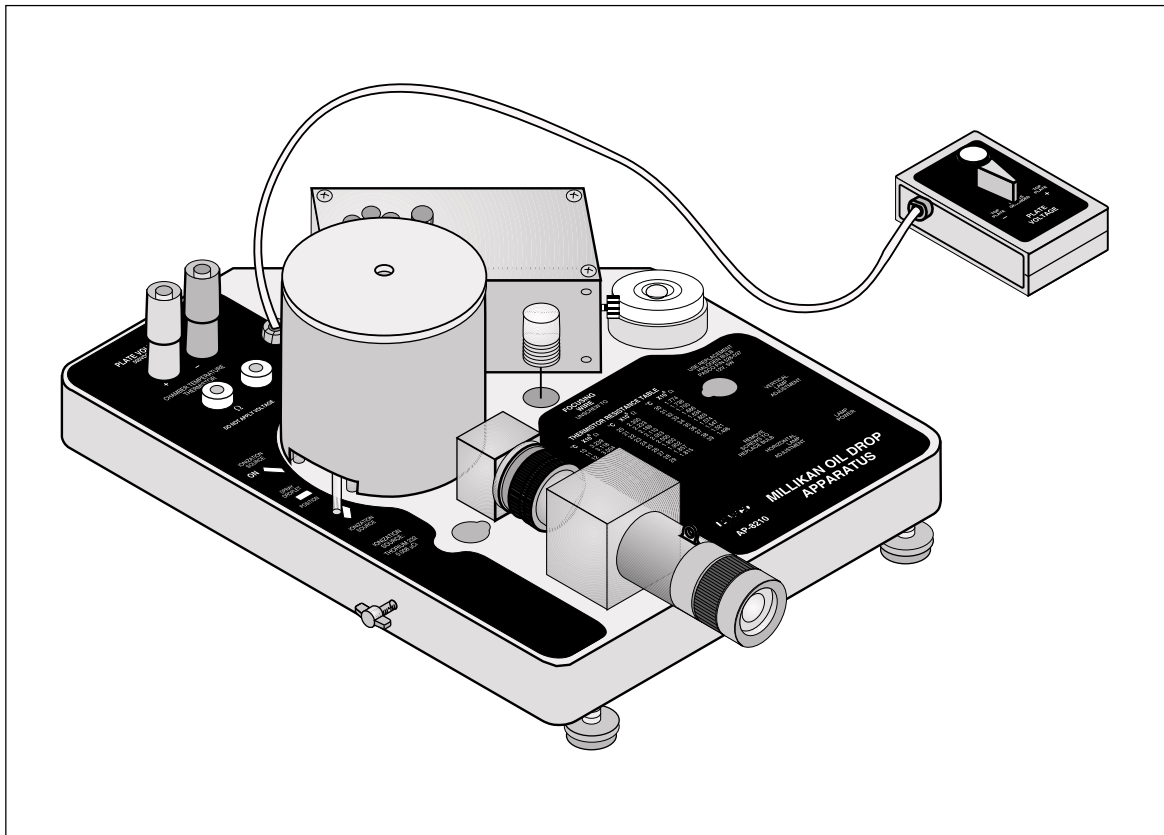



The exclamation point within an equilateral triangle is intended to alert the user of the presence of important operating and maintenance (servicing) instructions in the literature accompanying the appliance.

# Table of Contents

<b>Section</b>	<b>Page</b>
Copyright, Warranty, and Equipment Return .....	ii
Introduction .....	1–2
Equipment .....	3–4
Equipment Setup .....	5
Aligning the Optical System .....	6
Functions of Controls .....	6
Adjusting and Measuring the Voltage .....	7
Determining the Temperature of the Droplet Viewing Chamber .....	7
Experimental Procedure .....	7–9
Computation of the Charge of an Electron .....	9
Using a Projection Microscope with the Millikan Oil Drop Apparatus .....	10
Historical .....	11–15
 <b>Maintenance Notes</b>	
Cleaning .....	16
Replacing the Halogen Bulb .....	16
Adjusting the Vertical Reticle and Viewing Scope Alignments .....	16
Adjusting the Horizontal Reticle Alignment .....	17
Touching Up the Black Painted Surface on the Plastic Spacer .....	17
 <b>Appendix</b>	
A: Viscosity of Dry Air as a Function of Temperature .....	19
B: Thermistor Resistance at Various Temperatures .....	20
 <b>Teacher's Guide</b> .....	 21–24
 Technical Support .....	 Back Cover

# Copyright, Warranty and Equipment Return

**Please**—Feel free to duplicate this manual subject to the copyright restrictions below.

## Copyright Notice

The PASCO scientific 012-06123C manual is copyrighted and all rights reserved. However, permission is granted to non-profit educational institutions for reproduction of any part of the Millikan Oil Drop Experiment manual providing the reproductions are used only for their laboratories and are not sold for profit. Reproduction under any other circumstances, without the written consent of PASCO scientific, is prohibited.

## Limited Warranty

PASCO scientific warrants the product to be free from defects in materials and workmanship for a period of one year from the date of shipment to the customer. PASCO will repair or replace, at its option, any part of the product which is deemed to be defective in material or workmanship. The warranty does not cover damage to the product caused by abuse or improper use. Determination of whether a product failure is the result of a manufacturing defect or improper use by the customer shall be made solely by PASCO scientific. Responsibility for the return of equipment for warranty repair belongs to the customer. Equipment must be properly packed to prevent damage and shipped postage or freight prepaid. (Damage caused by improper packing of the equipment for return shipment will not be covered by the warranty.) Shipping costs for returning the equipment, after repair, will be paid by PASCO scientific.

## Credits

Editor: Sunny Bishop

## Equipment Return

Should the product have to be returned to PASCO scientific for any reason, notify PASCO scientific by letter, phone, or fax BEFORE returning the product. Upon notification, the return authorization and shipping instructions will be promptly issued.

► **NOTE: NO EQUIPMENT WILL BE ACCEPTED FOR RETURN WITHOUT AN AUTHORIZATION FROM PASCO.**

When returning equipment for repair, the units must be packed properly. Carriers will not accept responsibility for damage caused by improper packing. To be certain the unit will not be damaged in shipment, observe the following rules:

- ① The packing carton must be strong enough for the item shipped.
- ② Make certain there are at least two inches of packing material between any point on the apparatus and the inside walls of the carton.
- ③ Make certain that the packing material cannot shift in the box or become compressed, allowing the instrument come in contact with the packing carton.

Address: PASCO scientific  
10101 Foothills Blvd.  
Roseville, CA 95747-7100

Phone: (916) 786-3800  
FAX: (916) 786-3292  
email: techsupp@pasco.com  
web: www.pasco.com

# INTRODUCTION

The electric charge carried by a particle may be calculated by measuring the force experienced by the particle in an electric field of known strength. Although it is relatively easy to produce a known electric field, the force exerted by such a field on a particle carrying only one or several excess electrons is very small. For example, a field of 1000 volts per cm would exert a force of only  $1.6 \times 10^{-9}$  dyne on a particle bearing one excess electron. This is a force comparable to the gravitational force on a particle with a mass of  $10^{-12}$  (one million millionth) gram.

The success of the Millikan Oil Drop experiment depends on the ability to measure forces this small. The behavior of small charged droplets of oil, having masses of only  $10^{-12}$  gram or less, is observed in a gravitational and an electric field. Measuring the velocity of fall of the drop in air enables, with the use of Stokes' Law, the calculation of the mass of the drop. The observation of the velocity of the drop rising in an electric field then permits a calculation of the force on, and hence, the charge carried by the oil drop.

Although this experiment will allow one to measure the total charge on a drop, it is only through an analysis of the data obtained and a certain degree of experimental skill that the charge of a single electron can be determined. By selecting droplets which rise and fall slowly, one can be certain that the drop has a small number of excess electrons. A number of such drops should be observed and their respective charges calculated. If the charges on these drops are integral multiples of a certain smallest charge, then this is a good indication of the atomic nature of electricity. However, since a different droplet has been used for measuring each charge, there remains the question as to the effect of the drop itself on the charge. This uncertainty can be eliminated by changing the charge on a single drop while the drop is under observation. An ionization source placed near the drop will accomplish this. In fact, it is possible to change the charge on the same drop several times. If the results of measurements on the same drop then yield charges which are integral multiples of some smallest charge, then this is proof of the atomic nature of electricity.

The measurement of the charge of the electron also permits the calculation of Avogadro's number. The amount of current required to electrodeposit one gram equivalent of an element on an electrode (the faraday) is

equal to the charge of the electron multiplied by the number of molecules in a mole. Through electrolysis experiments, the faraday has been found to be  $2.895 \times 10^{14}$  electrostatic units per gram equivalent weight (more commonly expressed in the mks system as  $9.625 \times 10^7$  coulombs per kilogram equivalent weight). Dividing the faraday by the charge of the electron,

$$\frac{2.895 \times 10^{14} \text{ e.s.u./gm equivalent weight}}{4.803 \times 10^{-10} \text{ e.s.u.}}$$

yields  $6.025 \times 10^{23}$  molecules per gram equivalent weight, or Avogadro's number.

## EQUATION FOR CALCULATING THE CHARGE ON A DROP

An analysis of the forces acting on an oil droplet will yield the equation for the determination of the charge carried by the droplet.

Figure 1 shows the forces acting on the drop when it is falling in air and has reached its terminal velocity. (Terminal velocity is reached in a few milliseconds for the droplets used in this experiment.) In Figure 1,  $v_f$  is the velocity of fall,  $k$  is the coefficient of friction between the air and the drop,  $m$  is the mass of the drop, and  $g$  is the acceleration of gravity. Since the forces are equal and opposite:

$$mg = kv_f \quad (1)$$

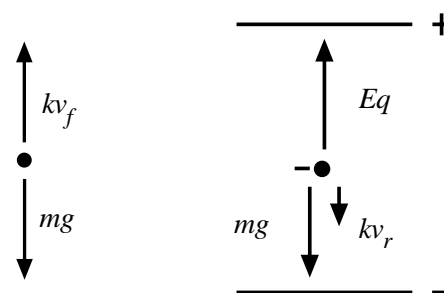

Figure 1

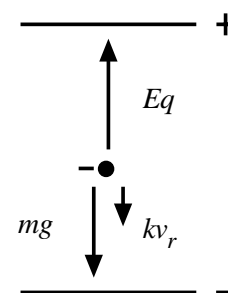

Figure 2

Figure 2 shows the forces acting on the drop when it is rising under the influence of an electric field. In Figure 2,  $E$  is the electric intensity,  $q$  is the charge carried by the drop, and  $v_r$  is the velocity of rise. Adding the forces vectorially yields:



$$Eq = mg + kv_r \quad (2)$$

In both cases there is also a small buoyant force exerted by the air on the droplet. Since the density of air is only about one-thousandth that of oil, this force may be neglected.

Eliminating  $k$  from equations (1) and (2) and solving for  $q$  yields:

$$q = \frac{mg(v_f + v_r)}{Ev_f} \quad (3)$$

To eliminate  $m$  from equation (3), one uses the expression for the volume of a sphere:

$$m = \frac{4}{3}\pi a^3 \rho \quad (4)$$

where  $a$  is the radius of the droplet, and  $\rho$  is the density of the oil.

To calculate  $a$ , one employs Stokes' Law, relating the radius of a spherical body to its velocity of fall in a viscous medium (with the coefficient of viscosity,  $\eta$ ).

$$a = \sqrt{\left(\frac{9\eta v_f}{2g\rho}\right)^2} \quad * \quad (5)$$

Stokes' Law, however, becomes incorrect when the velocity of fall of the droplets is less than 0.1 cm/s. (Droplets having this and smaller velocities have radii, on the order of 2 microns, comparable to the mean free path of air molecules, a condition which violates one of the assumptions made in deriving Stokes' Law.) Since the velocities of the droplets used in this experiment will be in the range of 0.01 to 0.001 cm/s, the viscosity must be multiplied by a correction factor. The resulting effective viscosity is:

$$\eta_{eff} = \eta \left(\frac{1}{1 + \frac{b}{pa}}\right) \quad ** \quad (6)$$

where  $b$  is a constant,  $p$  is the atmospheric pressure, and  $a$  is the radius of the drop as calculated by the uncorrected form of Stokes' Law, equation (5).

Substituting  $\eta_{eff}$  in equation (6) into equation (5), and then solving for the radius  $a$  gives:

$$a = \sqrt{\left(\frac{b}{2\rho}\right)^2 + \frac{9\eta v_f}{2g(\rho)}} - \frac{b}{2\rho} \quad (7)$$

Substituting equations (4), (5), and (6) into equation (3) yields:

$$q = 6\pi \sqrt{\frac{9\eta^3}{2g\rho \left(1 + \frac{b}{pa}\right)^3}} (v_f + v_r) \sqrt{v_f} \quad (8)$$

The electric intensity is given by  $E = V/d$ , where  $V$  is the potential difference across the parallel plates separated by a distance  $d$ .  $E$ ,  $V$ , and  $d$  are all expressed in the same system of units. If  $E$  is in electrostatic units,  $V$  in volts, and  $d$  in centimeters, the relationship is:

$$E \text{ (e.s.u.)} = \frac{V \text{ (volts)}}{300d \text{ (cm)}} \quad (9)$$

Substituting equations (7) and (8) into equation (6) and rearranging the terms yields:

$$q = \left[400\pi d \left(\frac{1}{g\rho} \left[\frac{9\eta}{2}\right]^3\right)^{1/2}\right] \cdot x \left[\left(\frac{1}{1 + \frac{b}{pa}}\right)^{3/2}\right] \cdot x \left[\frac{v_f + v_r \sqrt{v_f}}{V}\right] \text{ e.s.u.} \quad (10)$$

The terms in the first set of brackets need only be determined once for any particular apparatus. The second term is determined for each droplet, while the term in the third set of brackets is calculated for each change of charge that the drop experiences.

The definitions of the symbols used, together with their proper units for use in equation (9) are\*\*\*:

- $q$  – charge, in e.s.u., carried by the droplet
- $d$  – separation of the plates in the condenser in cm
- $\rho$  – density of oil in gm/cm<sup>3</sup>
- $g$  – acceleration of gravity in cm/s<sup>2</sup>
- $\eta$  – viscosity of air in poise (dyne s/cm<sup>2</sup>)
- $b$  – constant, equal to  $6.17 \times 10^{-4}$  (cm of Hg) (cm)
- $p$  – barometric pressure in cm of mercury.
- $a$  – radius of the drop in cm as calculated by equation (5)

$v_f$  – velocity of fall in cm/s

$v_r$  – velocity of rise in cm/s

$V$  – potential difference across the plates in volts

**Note:** The accepted value for  $e$  is  $4.803 \times 10^{-10}$  e.s.u., or  $1.60 \times 10^{-19}$  coulombs.

\*For additional information about Stokes' Law, the student is referred to *Introduction to Theoretical Physics*, by L. Page (New York, Van Nostrand), Chapter 6.

\*\* A derivation may be found in *The Electron* by R. A. Millikan (Chicago, The University of Chicago Press), Chapter 5.

\*\*\* Modern calculations of  $q$  are usually conducted in SI units. (See *Experimental Procedure, Computation of the Charge of an Electron*, page 7.)

# EQUIPMENT

**Included equipment:**

- apparatus platform and plate charging switch (see detailed description below and on page 4)
- 12 volt DC transformer for the halogen lamp
- non-volatile oil (Squibb #5597 Mineral Oil, density =  $886 \text{ kg/m}^3$ )\*
- atomizer

\* **Note:** We measured the density of the Squibb Mineral Oil and found it to be  $886 \text{ kg/m}^3$ . However, the densities of different lots of mineral oil may vary slightly; therefore, for greatest precision, you should determine the density of the mineral oil you are using.

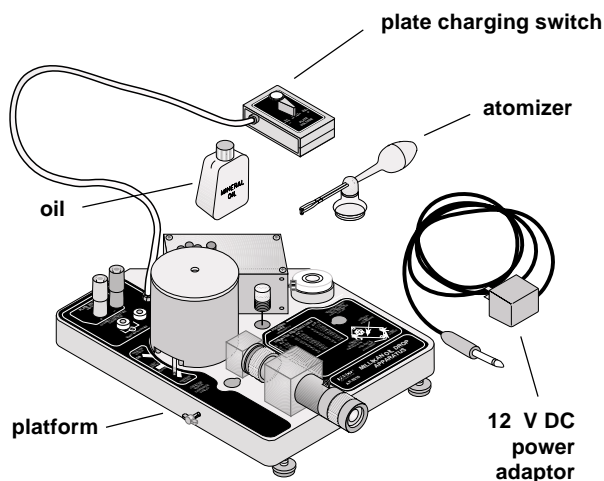

**Figure 3. Included equipment**

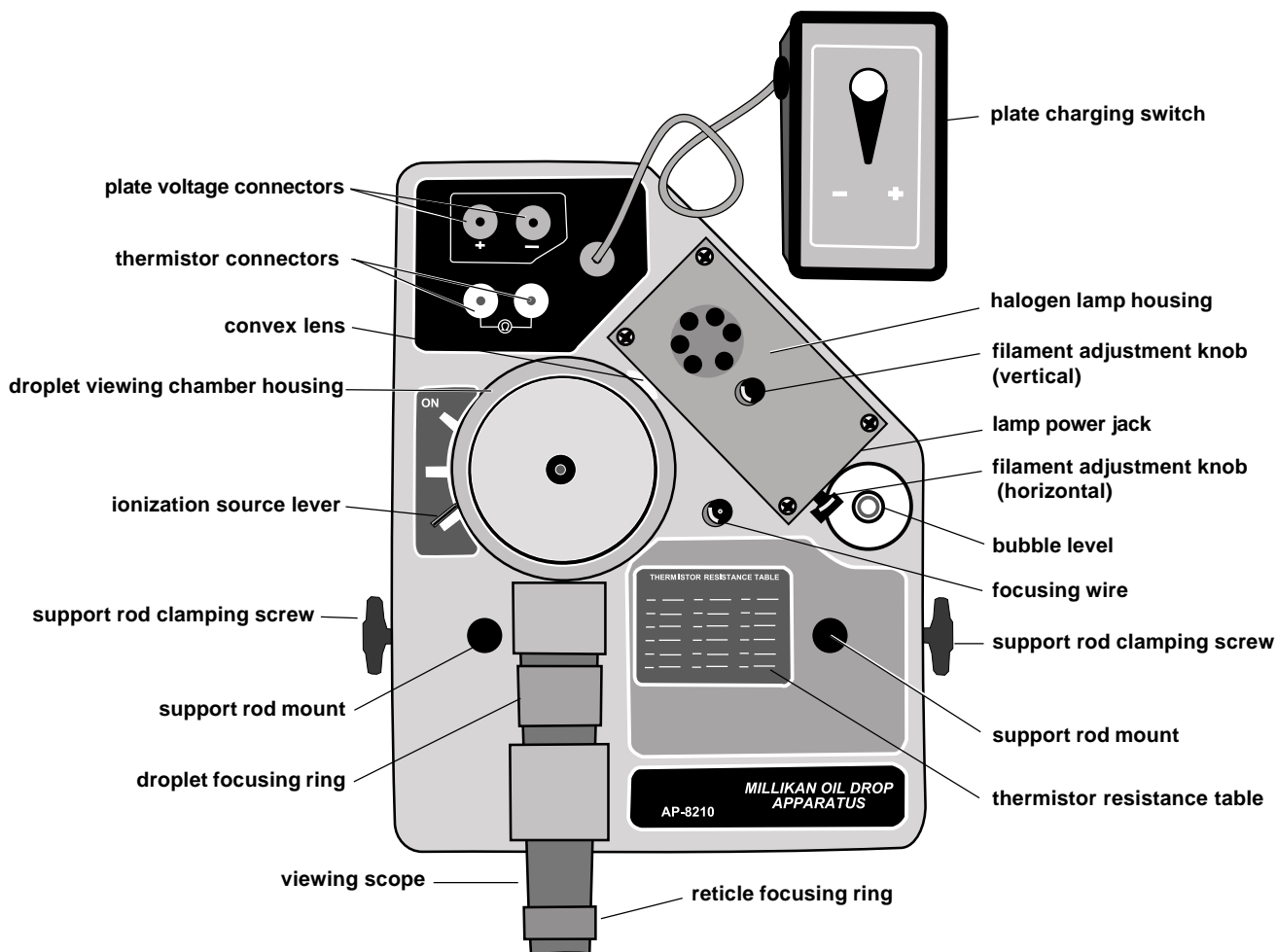

**Figure 4. Apparatus platform**

**Components of platform:**

- droplet viewing chamber (see details below)
- viewing scope (30X, bright-field, erect image) with reticle (line separation: 0.5 mm major divisions, 0.1 mm minor divisions), reticle focusing ring, and droplet focusing ring
- halogen lamp (12 V, 5 W halogen bulb and dichroic, infrared heat-absorbing window, horizontal and vertical filament adjustment knobs)
- focusing wire (for adjusting viewing scope)
- plate voltage connectors
- thermistor connectors (thermistor is mounted in the bottom plate)



**WARNING:** Do not apply voltage to the thermistor connectors.

- thermistor table (resistance versus temperature)
- ionization source lever (with three positions: Ionization ON, Ionization OFF, and Spray Droplet Position)
- bubble level
- support rod mounts and screws (to permit mounting of platform on a PASCO ME-8735 Large Rod Stand, so viewing scope can be raised to a comfortable eye level)
- 3 leveling feet
- plate charging switch (on a 1 meter cord to prevent vibration of platform during switching activity)

**Components of droplet viewing chamber (Figure 5)**

- lid
- housing
- droplet hole cover
- upper capacitor plate (brass)
- plastic spacer (approximately 7.6 mm thick)
- lower capacitor plate (brass)
  - thorium-232 alpha source (0.008 mcurie)
  - electrical connection to upper capacitor plate
- convex lens

**Note:** Thorium-232 is a naturally occurring, low level alpha-particle emitter with a half-life of  $1.41 \times 10^{10}$  years. It is not regulated in its use and poses no hazard to the user of the PASCO Millikan Oil Drop Apparatus.



It is recommended that you store the equipment in the original packing material. After unpacking, remove the foam insert from the droplet viewing chamber. Store the plate charging switch on the velcro tabs located on the platform.

**Required equipment, not included:**

- high voltage, well regulated power supply that delivers up to 500 V DC, 10 mA minimum (for example, the PASCO SF-9585 High Voltage Power Supply)
- digital multimeter (to measure voltage and resistance) (for example, the PASCO SB-9599A Universal Digital Multimeter)
- patch cords with banana plug connectors (4) (for example, the PASCO SE-9415 Banana Plug Patch Cord)
- stopwatch (for example, the PASCO SE-8702A Digital Stopwatch)

**Additional recommended equipment:**

- PASCO ME-8735 Large Rod Stand
- PASCO ME-8736 Steel Rods, 45 cm (2)

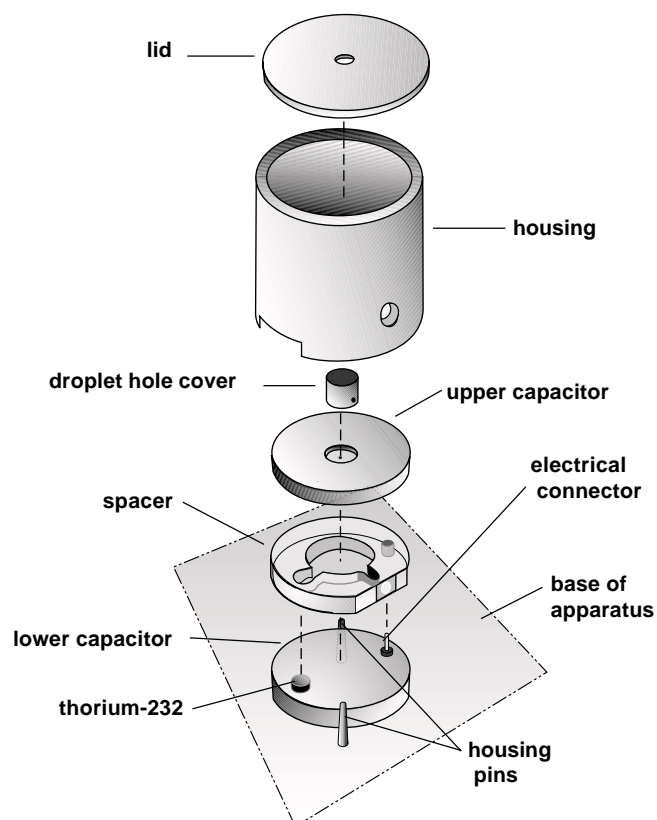

**Figure 5. Droplet viewing chamber**

## Equipment Setup

### Adjusting the environment of the experiment room

1. Make the room as dark as possible, while allowing for adequate light to read the multimeter and stopwatch, and to record data.
2. Insure that the background behind the apparatus is dark.
3. Select a location that is free of drafts and vibrations.

### Adjusting the height of the platform and leveling it

1. Place the apparatus on a level, solid table with the viewing scope at a height which permits the experimenter to sit erect while observing the drops. If necessary to achieve the proper height, mount the apparatus on two support rods (ME-8736) on the large rod stand (ME-8735) (Figure 6).
2. Using attached bubble level as a reference, level the apparatus with the leveling screws on the rod stand or the leveling feet of the platform, as is appropriate for your setup.

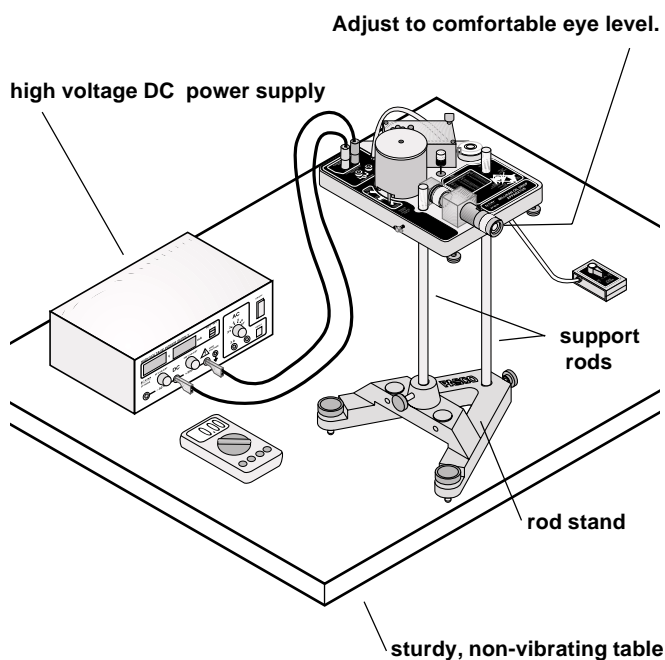

Figure 6. Equipment setup

### Measuring plate separation

1. Disassemble the droplet viewing chamber by lifting the housing straight up and then removing the upper capacitor plate and spacer plate. (See Figure 5.) Measure the thickness of the plastic spacer (which is equal to the plate separation distance) with a micrometer. Be sure that you are not including the raised rim of the spacer in your measurement. The accuracy of this measurement is important to the degree of accuracy of your experimental results. Record the measurement.



Use care when handling the brass plates and plastic spacer to avoid scratching them.



All surfaces involved in the measurement should be clean to prevent inaccurate readings.

## Aligning the Optical System

### Focusing the viewing scope

1. Reassemble the plastic spacer and the top capacitor plate onto the lower capacitor plate. Replace the housing, aligning the holes in its base with the housing pins. (See Figure 5.)

**Note:** The thorium source and the electrical connection on the lower capacitor plate fit into appropriately sized holes on the plastic spacer.

2. Unscrew the focusing wire from its storage place on the platform and carefully insert it into the hole in the center of the top capacitor plate (Figure 7).

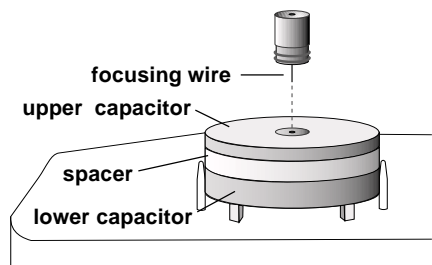

**Figure 7. Insertion of the focusing wire into the top capacitor plate**

3. Connect the 12 V DC transformer to the lamp power jack in the the halogen lamp housing and plug it into a wall socket.



Check to be sure that the transformer is the correct voltage: 100, 117, 220, or 240 V).

4. Bring the reticle into focus by turning the reticle focusing ring.
5. View the focusing wire through the viewing scope, and bring the wire into sharp focus by turning the droplet focusing ring.

**Note:** Viewing will be easier for experimenters who wear glasses if the viewing scope is focused without using the glasses.

### Focusing the halogen filament

1. Adjust the horizontal filament adjustment knob. The light is best focused when the right edge of the wire is

brightest (in highest contrast compared to the center of the wire).

2. While viewing the focusing wire through the viewing scope, turn the vertical filament adjustment knob until the light is brightest on the wire in the area of the reticle.
3. Return the focusing wire to its storage location on the platform.

## Functions of Controls

### Ionization source lever

1. When the lever is at the ionization **OFF** position, the ionization source is shielded on all sides by plastic, so that virtually no alpha particles enter the area of the drops.
2. At the **ON** position, the plastic shielding is removed and the drop area is exposed to the ionizing alpha particles emitted from the thorium-232.
3. At the **Spray Droplet Position**, the chamber is vented by a small air hole that allows air to escape when oil drops are being introduced to the chamber.

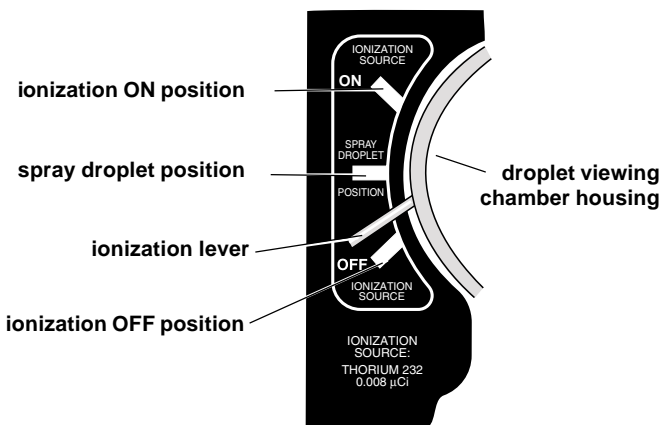

**Figure 8. Ionization source lever settings**

### Plate charging switch

The plate charging switch has three positions:

1. **TOP PLATE -**: negative binding post is connected to the top plate.
2. **TOP PLATE +**: negative binding post is connected to the bottom plate.
3. **PLATES GROUNDED**: plates are disconnected from the high voltage supply and are electrically connected.

## Adjusting and Measuring the Voltage

1. Connect the high voltage DC power supply to the plate voltage connectors using banana plug patch cords and adjust to deliver about 500 V.
2. Use the digital multimeter to measure the voltage delivered to the capacitor plates.



Measure the voltage at the plate voltage connectors, not across the capacitor plates. There is a 10 megohm resistor in series with each plate to prevent electric shock.

## Determining the Temperature of the Droplet Viewing Chamber

1. Connect the multimeter to the thermistor connectors and measure the resistance of the thermistor. Refer to the Thermistor Resistance Table located on the platform to find the temperature of the lower brass plate. The measured temperature should correspond to the temperature within the droplet viewing chamber.



Although the dichroic window reflects much of the heat generated by the halogen bulb, the temperature inside the droplet viewing chamber may rise after prolonged exposure to the light. Therefore, the temperature inside the droplet viewing chamber should be determined periodically (about every 15 minutes).

## Experimental Procedure

1. Complete the reassembly of the droplet viewing chamber by placing the droplet hole cover on the top capacitor plate and then placing the lid on the housing. (See Figure 5.)

**Note:** The droplet hole cover prevents additional droplets from entering the chamber once the experiment has started.

2. Measure and record the plate voltage and the thermistor resistance (temperature).

### Introducing the droplets into the chamber

1. Put non-volatile oil of known density into the atomizer (for example, Squibb #5597 Mineral Oil, density:  $886 \text{ kg/m}^3$ ).
2. Prepare the atomizer by rapidly squeezing the bulb until oil is spraying out. Insure that the tip of the atomizer is pointed down ( $90^\circ$  to the shaft; see Figure 9).

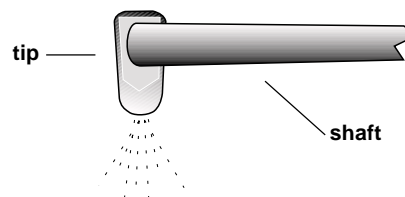

**Figure 9. Correct position of the atomizer tip**

3. Move the ionization source lever to the Spray Droplet Position to allow air to escape from the chamber during the introduction of droplets into the chamber.
4. Place the nozzle of the atomizer into the hole on the lid of the droplet viewing chamber.
5. While observing through viewing scope, squeeze the atomizer bulb with one quick squeeze. Then squeeze it slowly to force the droplets through the hole in the droplet hole cover, through the droplet entry hole in the top capacitor plate, and into the space between the two capacitor plates.
6. When you see a shower of drops through the viewing scope, move the ionization source lever to the OFF position.



If repeated “squirts” of the atomizer fail to produce any drops in the viewing area but produce a rather cloudy brightening of the field, the hole in the top plate or in the droplet hole cover may be clogged. Refer to the Maintenance section for cleaning instructions.

**Note:** The exact technique of introducing drops will need to be developed by the experimenter. The object is to get a small number of drops, not a large, bright cloud from which a single drop can be chosen. It is important to remember that the drops are being forced into the viewing area by the pressure of the atomizer. Therefore, excessive use of the atomizer can cause too many drops to be forced into the viewing area and, more important, into the area between the chamber wall and the focal point of the viewing scope. Drops in this area prevent observation of drops at the focal point of the scope.

**Note:** If the entire viewing area becomes filled with drops, so that no one drop can be selected, either wait three or four minutes until the drops settle out of view, or disassemble the droplet viewing chamber (after turning off the DC power supply), thus removing the drops. When the amount of oil on the parts in the droplet viewing chamber becomes excessive, clean them, as detailed in the Maintenance section. Remember: the less oil that is sprayed into the chamber, the fewer times the chamber must be cleaned.

### Selection of the Drop

1. From the drops in view, select a droplet that both falls slowly (about 0.02–0.05 mm/s) when the plate charging switch is in the “Plates Grounded” position and can be driven up and down by turning on the voltage.

**Hint:** A drop that requires about 15 seconds to fall the distance between the major reticle lines (0.5 mm) will rise the same distance, under the influence of an electric field (1000 V/cm), in the following times with the

following charges: 15 s, 1 excess electron; 7 s, 2 excess electrons; 3 s, 3 excess electrons. (Note: these ratios are only approximate.)

**Note:** If too many droplets are in view, you can clear out many of them by connecting power to the capacitor plates for several seconds.

**Note:** If you find that too few droplets have net charges to permit the selection of an appropriately sized and charged drop, move the ionization lever to the ON position for about five seconds.

2. When you find an appropriately sized and charged oil droplet, fine tune the focus of the viewing scope.

**Note:** The oil droplet is in best focus for accurate data collection when it appears as a pinpoint of bright light.

### Collecting Data on the Rise And Fall of the Oil Droplet

1. Measure the rise (plates charged) and fall (plates not charged) velocities of the selected droplet about 10–20 times. Maneuver the droplet as needed using the plate voltage switch.

**Note:** The greatest accuracy of measurement is achieved if you time from the instant that the bright point of light passes behind the first major reticle line to the instant bright point of light passes behind the second major reticle line. (These lines are 0.5 mm apart.)

2. Calculate the charge on the droplet. If the result of this first determination for the charge on the drop is greater than 5 excess electron, you should use slower moving droplets in subsequent determinations.
3. Introduce more oil droplets into the chamber using the procedure previously described and select another droplet.
4. Measure the rise and fall velocities of the selected droplet about 10–20 times or until the charge changes spontaneously or the droplet moves out of view.

- Bring the droplet to the top of the field of view and move the ionization lever to the ON position for a few seconds as the droplet falls.
- If the rising velocity of the droplet changes, make as many measurements of the new rising velocity as you can (10 to 20 measurements).
- If the droplet is still in view, attempt to change the charge on the droplet by introducing more alpha particles, as described previously, and measure the new rising velocity 10–20 times, if possible.
- Repeat step (7) as many times as you can.
- Record the plate potential, the oil density, the viscosity of air at the temperature of the droplet viewing chamber, (see appendix A), and the barometric pressure for each set of velocity measurements.

**Note:** It is desirable to observe as many different charges on a single drop as possible.

### Computation of the Charge of an Electron

- Use the formula derived in the Introduction to calculate the the charge of an electron\*:

$$q = \frac{4}{3}\pi\rho g \left[ \sqrt{\left(\frac{b}{2p}\right)^2 + \frac{9\eta v_f}{2g\rho}} - \frac{b}{2p} \right]^3 \frac{v_f + v_r}{Ev_f}$$

\*The formula is derived from equation 10 (page 2), using SI units as defined below.

The definitions of the symbols used, in SI units:

- $q$  – charge, in coulombs, carried by the droplet
- $d$  – separation of the plates in the condenser in m
- $\rho$  – density of oil in kg/m<sup>3</sup>
- $g$  – acceleration of gravity in m/s<sup>2</sup>
- $\eta$  – viscosity of air in poise (Ns/m<sup>2</sup>) (Appendix A)
- $b$  – constant, equal to  $8.20 \times 10^{-3}$  Pa · m
- $p$  – barometric pressure in pascals
- $a$  – radius of the drop in m
- $v_f$  – velocity of fall in m/s
- $v_r$  – velocity of rise in m/s
- $V$  – potential difference across the plates in volts

**Note:** The accepted value for  $e$  is  $1.60 \times 10^{-19}$  coulombs.

### Suggested Procedure for Computation of the Charge of an Electron:

- Using equation (7) (page 2), calculate the radius ( $a$ ) of the oil drop:

$$a = \sqrt{\left(\frac{b}{2p}\right)^2 + \frac{9\eta v_f}{2g\rho}} - \frac{b}{2p}$$

- Substitute  $a$  from the above equation to find the mass ( $m$ ) of the oil droplet:

$$m = \frac{4}{3}\pi a^3 \rho$$

$$= \frac{4}{3}\pi \left[ \sqrt{\left(\frac{b}{2p}\right)^2 + \frac{9\eta v_f}{2g\rho}} - \frac{b}{2p} \right]^3 \rho$$

- Substitute  $m$  from the calculation above into equation (3) (page 2) to find the charge carried by the droplet ( $q$ ):

$$q = \frac{mg(v_f + v_r)}{Ev_f}$$

$$= \frac{4}{3}\pi\rho g \left[ \sqrt{\left(\frac{b}{2p}\right)^2 + \frac{9\eta v_f}{2g\rho}} - \frac{b}{2p} \right]^3 \frac{(v_f + v_r)}{Ev_f}$$

**Note:** Equation (10) (page 2) is equivalent to the above equation, since

$$E(\text{e.s.u.}) = \frac{V(\text{volts})}{300d(\text{cm})}$$



## Using a Projecting Microscope with the Millikan Oil Drop Apparatus

To demonstrate Millikan's experiment for an entire classroom on a TV screen or computer monitor, use a projecting microscope, such as the Ken-A-Vision VideoFlex Microscope (PASCO Model No. SE-7227).

### Procedure:

#### 1. Put a white paper screen in the droplet viewing chamber to reflect more light:

- Prior to focusing the viewing scope (step 1 under the **Equipment Setup** section, *Aligning the Optical System*), place a white paper screen in the droplet viewing chamber as illustrated in Figure 10.

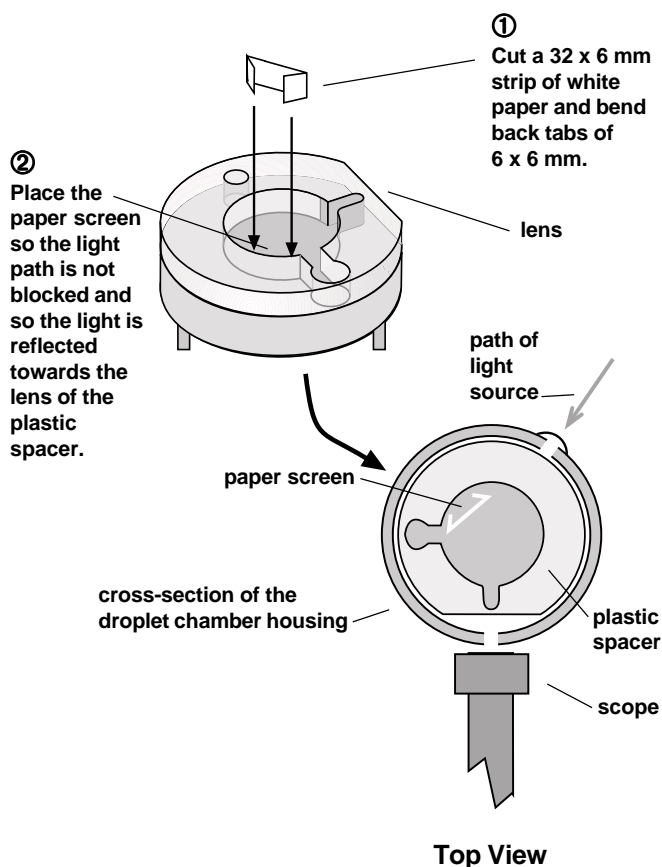

Figure 10. Placing a white paper screen in the droplet viewing chamber to increase the brightness of the oil drop image

- Proceed with step 1 of *Aligning the Optical System*.

#### 2. Align and focus the projecting microscope:

- Set up the projecting microscope as directed in the manufacturer's instructions.
- After completing the setup and focusing of the Millikan Apparatus on the oil droplets, carefully slide the eyepiece of the projecting microscope over the eyepiece of the Millikan Apparatus.
- Focus the projecting microscope as directed in the manufacturer's instructions.

# Historical

## HISTORICAL NOTES

The Greeks were the first to report the effects of electricity when they recorded that rubbed amber attracted light objects. However, theories explaining this phenomenon did not emerge until 1747, when Benjamin Franklin proposed that an electrical fluid or fire existed in certain amounts in all matter. An excess of this fluid in matter would produce a positive charge and a deficiency of this fluid would produce a negative charge. A slightly different theory was put forth by the physicist Symmer twelve years later. He proposed that matter in a neutral state shows no electrical properties because it contains equal amounts of two weightless fluids, which were called positive and negative electricity respectively.

Franklin also postulated the existence of an electrical particle small enough to easily permeate matter. Faraday's experiments in electrolysis, which demonstrated that when a current is passed through an electrolyte, the masses of compounds deposited at opposite electrodes are in proportion to the chemical equivalent weights of the compounds, also supported Franklin's concept of an elementary electrical particle. The fluid theories, along with a theory explaining electricity as a state of strain in matter, were the prime explanations of electrical phenomena until late in the 19th century.

### EARLY DETERMINATIONS OF $e$

The word "electron" was first suggested in 1891 by Dr. G. Johnstone Stoney as a name for the "natural unit of electricity," namely, that quantity of electricity that must pass through a solution in order to liberate at one electrode one atom of hydrogen or any univalent substance. It would follow that the charge of the electron multiplied by the number of molecules in a gram mole would give the amount of electricity required to deposit one gram mole by electrolysis. This quantity had been determined by Faraday to be 9650 absolute electromagnetic units of electricity. Using this method, Stoney obtained a value of  $0.3 \times 10^{-10}$  e.s.u. (The Kinetic Theory provided the basis for Stoney's estimation of Avogadro's number).

The first experimental attempt to measure the charge of an ion was made by Townsend in the late 1890's. He had observed that during electrolysis of sulfuric

acid, positively charged hydrogen and oxygen gasses were produced (although there were one million million neutral molecules to every charged one). This method was used to produce an ionized gas that was then bubbled through water to form a cloud. For his determination of  $e$  Townsend proceeded in the following manner:

1. He assumed that in saturated water vapor each ion condensed moisture about it, so that the number of ions was the same as the number of droplets.
2. He determined with the aid of a quadrant electrometer the total electrical charge per cubic centimeter carried by the gas.
3. He found the total weight of the cloud by passing it through drying tubes and determining the increase in weight of these tubes.
4. He found the average weight of the water droplets constituting the cloud by observing their rate of fall under gravity and computing their mean radius with the aid of a purely theoretical law known as Stokes' Law.
5. He divided the weight of the cloud by the average weight of the droplets of water to obtain the number of droplets which, if assumption 1 is correct, was the number of ions, and he then divided the total charge per cubic centimeter in the gas by the number of ions to find the average charge carried by each ion, that is, to find  $e$ .<sup>1</sup>

Townsend achieved results in the range of  $3 \times 10^{-10}$  e.s.u. for  $e$ . J. J. Thompson, in 1900, used a method similar to Townsend's and obtained a value of  $6 \times 10^{-10}$  e.s.u. In both of these methods, however, the first assumption (each droplet formed around only one ion) proved to be only approximately correct, and the experimental methods were not adequate to provide a precise determination of  $e$ .

H.S. Wilson improved upon Townsend's and Thompson's work by adding two brass plates which could be connected to a 2000 volt battery. A cloud was formed between these plates (not charged) and the falling velocity

<sup>1</sup> condensed from Robert A. Millikan's book, *The Electron* (University of Chicago Press, Chicago, 1993, pp. 45-46) and used with permission of the publishers.

of the cloud recorded. A second cloud was then formed and its falling velocity observed in an electric field (the plates being charged). Since the two velocities are proportional to the forces acting on the drops<sup>2</sup>, and the velocity of the cloud with the plates uncharged determines the size and mass of the drops by Stokes' Law, Wilson was able to obtain a value of  $3 \times 10^{-10}$  e.s.u. for  $e$ . Since Wilson's measurements were always made on the top of the cloud, or the drops with the smallest charge (the more heavily charged drops being driven downward faster in the field), the assumption of one ion per drop was validated.

### MILLIKAN'S DETERMINATION OF $e$

Millikan improved upon Wilson's design by using a higher potential across the plates so that the falling velocity of the cloud could not only be impeded, but actually reversed. Some charged drops moved upward, some moved rapidly downward, while the uncharged drops were unaffected and continued to drift downward. A few drops, which carried a charge of the proper magnitude so that the force of gravity on the drop almost equaled the force of the electric field on the drop, remained in view. By varying the potential of the plates, Millikan could just balance these drops. This situation proved to be a significant improvement for it permitted all measurements to be made on a single drop. By using this balanced drop method, Millikan was able to observe the properties of individual ions and to determine whether different ions carry one and the same charge.

In the following passage, taken from the "Philosophical Magazine" for February, 1910, Millikan describes the actual procedure of the experiment.

"The observations on the rate of fall were made with a short-focus telescope placed about 2 feet away from the plates. In the eyepiece of this telescope were placed three equally spaced cross-hairs. . . . A small section of the space between the plates was illuminated by a narrow beam from an arc light, the heat of the arc being absorbed by three water cells in series. The air between the plates was ionized by 200 mg of radium of activity 20,000

<sup>2</sup> With the plates uncharged the force is  $mg$  where  $m$  is the mass of the drop and  $g$  is the acceleration of gravity. With the plates charged the force is  $mg \pm Ee_n$  where  $E$  is the electric intensity between the plates and  $e_n$  is the charge on the drop.

<sup>3</sup> The italicized phrases indicate a slight change in wording, for purposes of clarity, from Millikan's original work.

placed from 3 to 10 cm away from the plates. A second or so after *the cloud was produced*<sup>3</sup> the radium was removed . . . and the field thrown on by means a double-throw switch. If the drops were not found to be held suspended by the field the *potential difference* was changed . . . . The cross-hairs were set near the lower plate, and as soon as a stationary drop was found somewhere above the upper cross-hair, it was watched for a few seconds to make sure that it was not moving and then the field was thrown off and the plates short-circuited by means of the double-throw switch, so as to make sure that they retained no charge. The drop was then timed by means of an accurate stop watch as it passed across the three cross-hairs, one of the two hands of the watch being stopped at the instant of passage across the middle cross-hair, and the other at the instant of passage across the lower one. It will be seen that this method of observation furnishes a double check upon evaporation; for if the drop is stationary at first, it is not evaporating sufficiently to influence the reading of the rate of fall, and if it begins to evaporate appreciably before the reading is completed, the time required to pass through the second space should be greater than that required to pass through the first space. It will be seen from the observations which follow that this was not, in general, the case.

It is an exceedingly interesting and instructive experiment to watch one of these drops start and stop, or even reverse its direction of motion, as the field is thrown off and on. I have often caught a drop which was just too light to remain stationary and moved it back and forth in this way four or five times between the same two cross-hairs, watching it first fall under gravity when the field was thrown off and then rise against gravity when the field was thrown on . . . .

Furthermore, since the observations . . . are all made upon the same drop, all uncertainties as to whether conditions can be exactly duplicated in the formation of successive clouds obviously disappear. There is no theoretical uncertainty whatever left in the method unless it be an uncertainty as to whether or not Stokes' Law applies to the rate of fall of these drops under gravity."

Experiments with the balanced water drop produced the value of  $3.422 \times 10^{-10}$  e.s.u. for  $e$ . The most important aspect of these experiments, however, was the observation by Millikan that a rising drop would suddenly change its velocity. This phenomenon could easily be produced by placing a radioactive source near the drop. This demonstrated that the drop had "captured" an ion, thus changing the charge of the drop and its respective velocity.

## THE EXACT EVALUATION OF $e$

In 1909 Millikan set about building a new piece of apparatus designed for the observation of single oil drops for extended periods of time. Since water drops had proved inadequate for prolonged observation of this ion catching phenomenon, Millikan used oil drops, which were not affected by evaporation. The apparatus consisted of two parallel brass plates separated by a distance of 16 mm by ebonite blocks. Non-volatile oil was sprayed into the chamber above the plates, and small drops slowly found their way into the area between the plates through a small hole in the top plate. The drops were illuminated by a beam from a carbon arc lamp and were observed through a measuring scope. The details of the construction of Millikan's final apparatus built in 1914 (which was basically similar to his earlier devices, and for the purposes of this discussion can be considered the same as the earlier pieces of apparatus) attest to the effort expended in obtaining the most accurate evaluation

of  $e$  possible. The following passage is part of Millikan's description of the apparatus, including a diagram of the device.

"Accordingly, I built two years ago a new condenser having surfaces which were polished optically and made flat to within two wave-lengths of sodium light. They were 22 cm. in diameter and were separated by three pieces of echelon plates, 14.9174 mm. thick, and having optically perfect plate surfaces. The dimensions of the condenser, therefore, no longer introduced an uncertainty of more than about 1 part in 10,000."<sup>5</sup>

"Complete stagnancy of the air between the condenser plates was attained, first, by absorbing all the heat rays from the arc lamp by means of a water cell 80 cm. long, and a cupric chloride cell, and secondly, by immersing the whole vessel in a constant temperature bath of gas-engine oil (40 liters), which permitted, in general, fluctuations of not more than 0.02 °C during an observation."<sup>6</sup>

Diagram of Millikan's Apparatus<sup>7</sup>

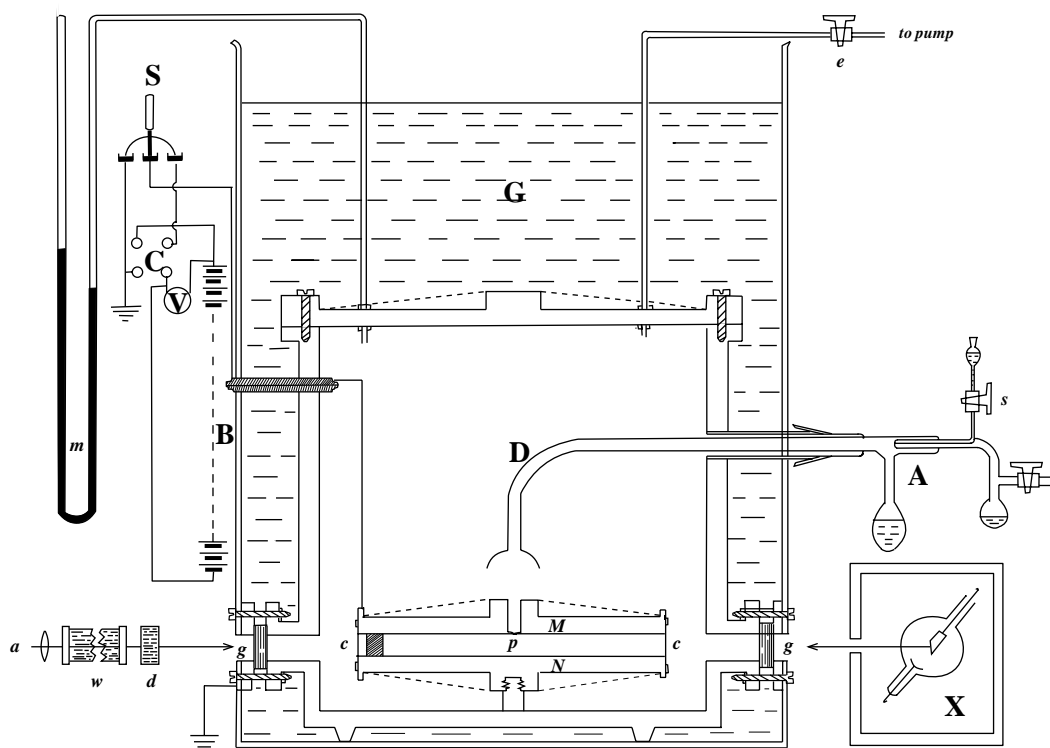

Fig. 11.—A, atomizer through which the oil spray is blown into the cylindrical vessel D. G, oil tank to keep the temperature constant. M and N, circular brass plates, electrical field produced by throwing on 10,000-volt battery B. Light from arc lamp a after heat rays are removed by passage through w and d, enters chamber through glass window g and illuminates droplet, p between plates M and N through the pinhole in M. Additional ions are produced about p by X-rays from the bulb X.

<sup>5</sup>Millikan, Robert A., p. 115.

<sup>6</sup>Millikan, Robert A., p. 110.

<sup>7</sup>Millikan, Robert A., p. 116.

With this new apparatus hundreds of measurements on different drops were made, for the purpose of both making an exact evaluation of  $e$  and proving or disproving the atomic theory of electricity. The value of  $e$  that was obtained from these five years of work was  $4.774 \times 10^{-10}$  e.s.u. This value of  $e$  was accepted until 1928 when a precise determination of Avogadro's number by X-ray diffraction measurements on crystals permitted the calculation of  $e$  to be  $4.803 \times 10^{-10}$  e.s.u. The discrepancy was later traced to Millikan's too low value for the viscosity of air.

### ATOMIC NATURE OF ELECTRICITY

The atomic nature of electricity is best exemplified by the following table taken from Millikan's data:

n	4.917 x n	Observed Charge
1	4.917	....
2	9.834	....
3	14.75	....
4	19.66	19.66
5	24.59	24.60
6	29.50	29.62
7	34.42	34.47
8	39.34	39.38
9	44.25	44.42
10	49.17	49.41
11	54.09	53.91
12	59.00	59.12
13	63.92	63.68
14	68.84	68.65
15	73.75	....
16	78.67	78.34
17	83.59	83.22
18	88.51	....

Millikan makes the following comments about this table.

"In this table 4.917 is merely a number obtained . . . from the change in speed due to the capture of ions and one which is proportional in this experiment to the ionic

charge. The column headed 4.917 x n contains simply the whole series of exact multiples of this number from 1 to 18. The column headed 'Observed Charge' gives the successive observed values of the rising velocity of the drop plus the falling velocity. It will be seen that during the time of observation, about four hours, this drop carried all possible multiples of the elementary charge from 4 to 17, save only 15. No more exact or more consistent multiple relationship is found in the data which chemists have amassed on the combining powers of the elements and on which the atomic theory of matter rests than is found in the foregoing numbers.

Such tables as these—and scores of them could be given—place beyond all question the view that an electrical charge wherever it is found, whether on an insulator or conductor, whether in electrolytes or in metals, has a definite granular structure, that it consists of an exact number of specks of electricity (electrons) all exactly alike, which in static phenomena are scattered over the surface of the charged body and in current phenomena are drifting along the conductor. Instead of giving up, as Maxwell thought we should some day do, the 'provisional hypothesis of molecular charges,' we find ourselves obliged to make all our interpretations of electrical phenomena, metallic as well as electrolytic, in terms of it."<sup>9</sup>

Although the values of the charge on a specific drop were found to be exact multiples of a certain value ( $e$ ), the value of  $e$  varied for drops of different masses. This discrepancy was traced to the breakdown of Stokes' Law. Through experimentation the law was found to fail when the size of the drop approached the mean free path of air molecules. When this situation occurs, the medium in which the drop falls is no longer homogeneous in relation to the drop. This contradicts one of the assumptions upon which Stokes' Law is based. Through his work on the electron, Millikan was able to determine a correction factor for Stokes' Law.

By performing the experiment with mercury drops and drops of other materials, Millikan demonstrated that the elementary electrical charge was the same for insulators, semi-conductors, and conductors. He also demonstrated that the beta particle had the same charge as an electron (indeed, it is an electron) and that positive and negative

<sup>8</sup>Millikan, Robert A., p. 74.

<sup>9</sup>Millikan, Robert A., pp. 74–75.

electrons (the positive electron referring to a proton and not a positron) are equal in charge. The experiment also produced insights into the study of ionized gasses.

Few experiments that are so simple in principle have provided such a wealth of experimental evidence to confirm the atomic theory and measure an important physical constant.

### **Suggested Reading**

Should the student desire a more detailed back ground in this classic experiment, the following references are suggested:

1. Millikan, Robert A., *The Electron*, (Chicago, The University of Chicago Press, 1917 (reprinting in paperback form, 1963).
2. Millikan, Robert A., "The Isolation of an Ion, A Precision Measurement of its Charge, and the Correction of Stokes' Law," *The Physical Review*, Vol. 2, No. 2, pp. 109 – 143, June 1913.
3. Millikan, Robert A., "On the Elementary Electrical Charge and the Avogadro Constant," *The Physical Review*, Vol. 32, No. 4, pp. 349 – 397, April, 1911.
4. Shamos, M.H., *Great Experiments in Physics* (Holt-Dryden, New York, 1959), pp. 238 – 249.

# Maintenance Notes

## Cleaning

1. The housing of the droplet viewing chamber, the capacitor plates, the plastic spacer, and the droplet hole cover should be cleaned with water and detergent, with particular attention to the droplet hole in the top capacitor plate, the glass observation port covers on the housing, and the droplet hole cover.
2. The plastic spacer should be polished with a soft, lint-free cloth to remove any oil, finger prints, or lint.
3. The lens on the plastic spacer should be cleaned on both sides using a Q-tip.
4. Apply a thin film of oil to the capacitor plates to help prevent corrosion.
5. Dry all parts completely before reassembly.

 Always handle the plastic spacer and capacitor plates carefully to avoid scratching them.

 Solvents that might attack the plastic should be avoided.

## Replacing the halogen light bulb

1. Disconnect the apparatus from all power sources.
2. Remove the four screws on the halogen lamp housing and lift off the top cover. Gently pull the halogen bulb out of its socket.
3. Replace with a GE #18426 halogen bulb (12 V, 5 W, T3 type with 2-Pin G4 base, C6 straight filament). Carefully insert the pins at the base of the bulb into the socket and press firmly to seat the bulb securely.

 Handle the new halogen bulb only with tissue paper—oil on the hands may damage the bulb.

## Adjusting vertical reticle and viewing scope alignments

If the alignment of the reticle or viewing scope is altered during rough handling, realign it using the following procedure:

1. Loosen the set screw in the viewing scope holder (Figure 12).

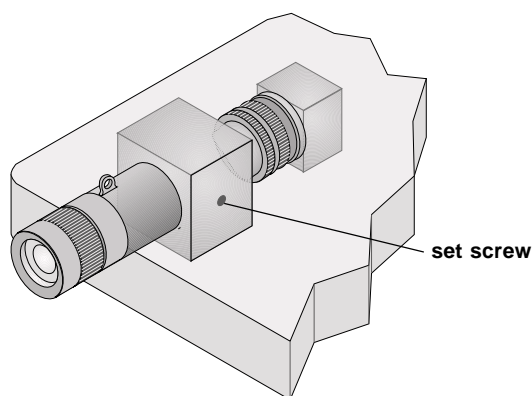

**Figure 12. Location of viewing scope set screw**

2. With the focusing wire in place and while looking through the eyepiece, rotate the viewing scope until the vertical reticle lines are vertical to the focusing wire.
3. Find the center of focus in the adjustment knob on the viewing scope (this will be approximately half-way between minimum and maximum focus).
4. Manually move the viewing scope in and out through its holder until the focusing wire comes into focus.
5. Recheck the reticle to assure that it is still in proper alignment with the focusing wire (as in step 2).
6. Lock the viewing scope into position by tightening the set screw into the viewing scope holder.

### Adjusting the horizontal reticle alignment

If the horizontal alignment of the viewing scope is altered during rough handling, realign it using the following procedure:

1. Loosen one of the two socket head cap screws on the bottom of the platform shown in Figure 13.
2. With the focusing wire in place and while looking through the eyepiece, gently tap the viewing scope until the focusing wire is centered in the reticle.



Only a very small adjustment will be required. Use care to avoid losing sight of the focusing wire.

3. Lock the viewing scope into position by tightening the two socket head cap screws into the viewing scope holder.

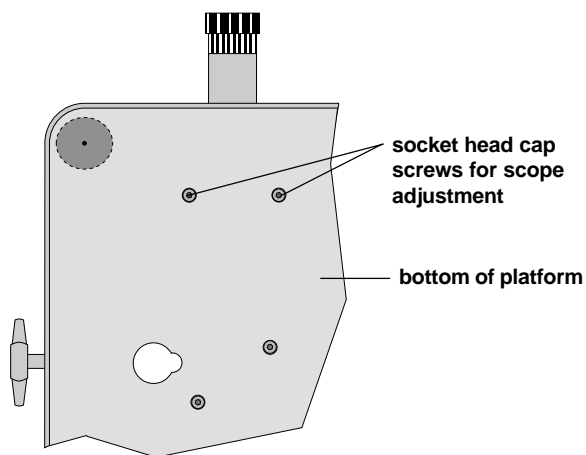

**Figure 13.** Location of the socket head cap screws that anchor the viewing scope

### Touching up the black painted surface on the plastic spacer

After prolonged use and repeated cleaning, the black paint (Figure 14) that absorbs refracted and reflected light on the plastic spacer may begin to wear off. In that event, touch up the surface with a thin coat of flat black acrylic paint such as that available at hobby stores. Do not use a lacquer or oil-based paint.



Do not allow paint to get on the top and bottom flat surfaces of the plastic spacer, since that would change the plate spacer thickness.

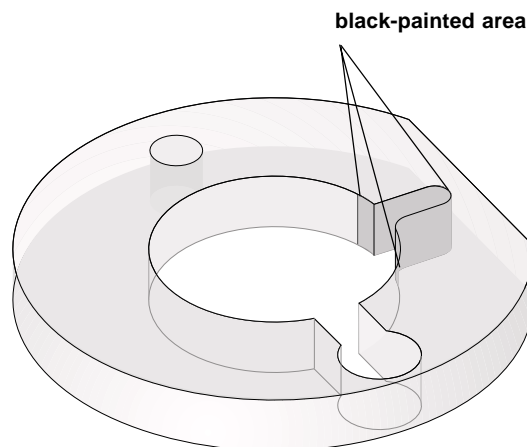

**Figure 14.** Area on the plastic spacer that should be painted black



---

**Notes**

# Appendix

## Appendix A: Viscosity of Dry Air as a Function of Temperature\*

Viscosity of Dry Air as a Function of Temperature

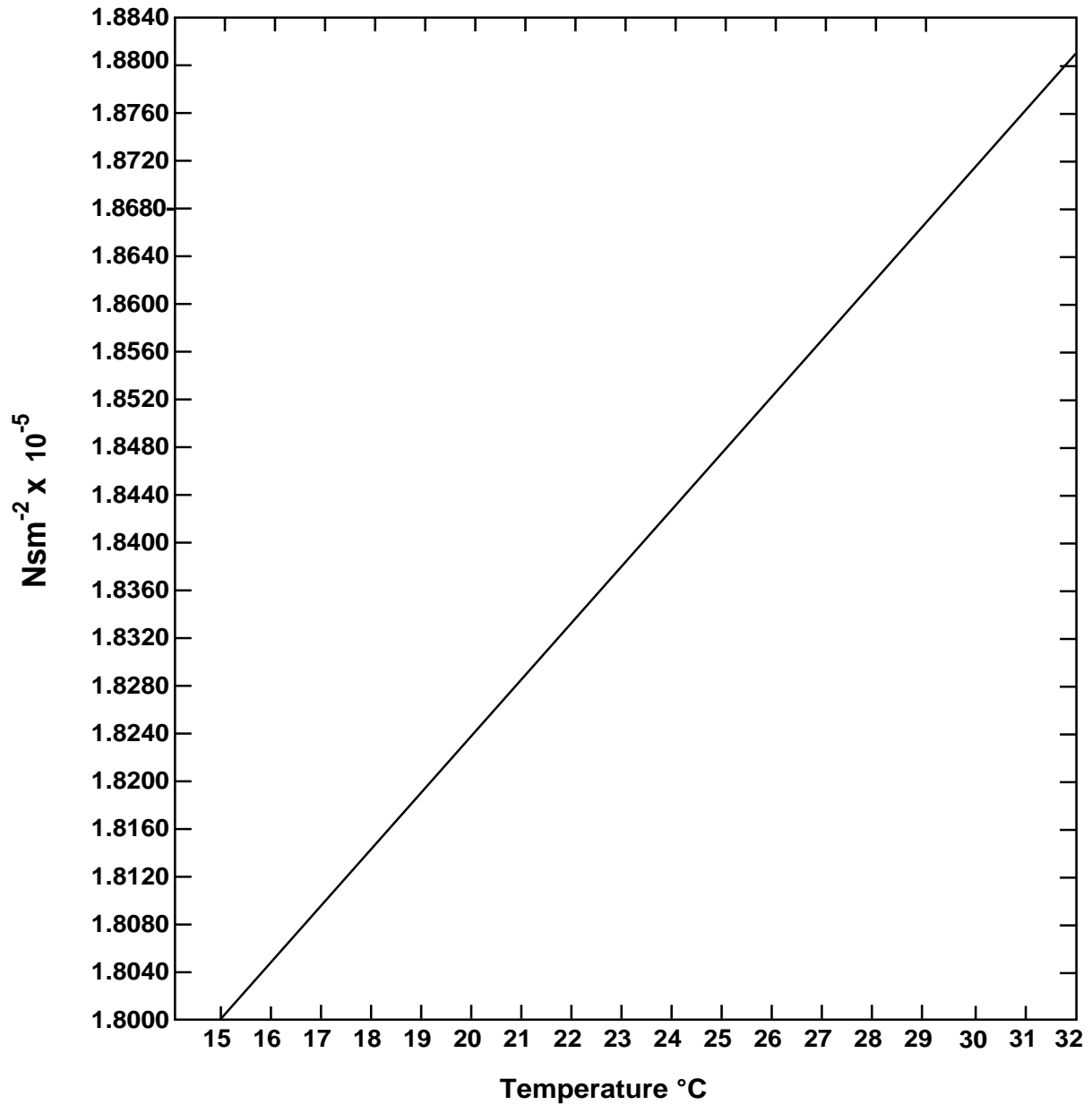

**Appendix B:**

**Millikan Oil Drop Apparatus Thermistor Resistance at Various Temperatures**

<b>THERMISTOR RESISTANCE TABLE</b>					
<b>°C</b>	<b>X 10<sup>6</sup> Ω</b>	<b>°C</b>	<b>X 10<sup>6</sup> Ω</b>	<b>°C</b>	<b>X 10<sup>6</sup> Ω</b>
10	3.239	20	2.300	30	1.774
11	3.118	21	2.233	31	1.736
12	3.004	22	2.169	32	1.700
13	2.897	23	2.110	33	1.666
14	2.795	24	2.053	34	1.634
15	2.700	25	2.000	35	1.603
16	2.610	26	1.950	36	1.574
17	2.526	27	1.902	37	1.547
18	2.446	28	1.857	38	1.521
19	2.371	29	1.815	39	1.496

## Teachers Guide

► **Note:** It is best that students work in pairs—one to observe the drop and one to record the experimental data.

► **Note:** Leveling will be most accurate if the bubble level is observed from directly above during leveling.

► **Note:** If more accuracy with leveling is needed to prevent the oil droplets from gradually drifting off to one side during prolonged observations, perform the leveling operation using a two-dimensional level or ball bearing placed directly on the bottom capacitor plate.

As an example of typical experimental results, the following pages list one teacher's data, using the alternative method for calculating the charge on an electron that is presented on page 9. The teacher measured the velocity of the drop moving down with the plates charged and used the method listed below to organize the data for computation.

For each different charge event for a drop the following was done:

1. Measured the velocity of the falling drop with the plates not charged, the velocity of the rising drop with the plates charged, and the velocity of the falling drop with the plates charged;
2. Assigned a "charge letter" to each event of differing charge for each oil droplet; for example, for drop 1: 1A, 0 (velocity of the falling drop with the plates not charged), 1B, u (velocity of the rising drop), 1B, d (velocity with the plates charged of the falling drop), 1C, u, d, and 1D, u, d ; for droplet 2: 2A0, u, d, 2B u, d, 2C u, d, and so on.
3. Averaged all measurements for a drop falling with the plates not charged, for use to determine  $a$ ;
4. For each charge letter, averaged the measurements for the cases of the drop rising or falling with the plates charged;
5. Calculated the average charges on each droplet for each charge letter (averaging the charges for the cases with the droplet rising and with the droplet falling while the plates were charged);
6. Listed the average charges for the charge letters in order of increasing size and calculated the average difference between charges;
7. Calculated the number of  $e$  for droplet under each of the charge conditions by dividing the average charge for each charge letter by the average difference in charge from step 5, above.

The data and calculations for measurements on one droplet are listed on the following pages.

Sample Data for Millikan Apparatus: Voltage = 386 V; Temperature = 28.8° C

Drop# / Charge Letter	Distance timed (mm)	Time (s)	Direction: 0 = no field U = going up D = going down
1A	0.5	18.24	0
	0.5	18.56	0
	0.5	19.24	0
	0.5	18.05	0
	0.5	17.23	0
	0.5	15.35	0
	0.5	16.70	0
	0.5	17.99	0
	0.5	15.35	0
	0.5	17.25	0
	0.5	18.38	0
1C	0.5	18.32	0
1D	0.5	16.56	0
	0.5	18.70	0
	0.5	16.56	0
	1.0	33.63	0
	0.5	17.30	0
	0.5	19.06	0
	0.5	18.33	0
	0.5	16.21	0
	0.5	15.36	0
	0.5	15.70	0
	0.5	17.10	0
	0.5	17.30	0
	0.5	17.80	0

Average Time with no field = 17.34 s for 0.5 mm

Drop# / Charge Letter	Distance timed (mm)	Time (s)	Direction: 0 = no field U = going up D = going down	Average Times (s) for a distance of 0.5 mm
1A	0.5	3.89	U	
	1.5	11.00	U	
	1.5	11.59	U	
	1.5	11.17	U	3.79 U
	0.5	2.66	D	
	1.5	7.84	D	2.64 D
1B	1.5	8.32	U	
	1.5	8.20	U	2.75 U
	1.5	6.20	D	
	1.5	6.02	D	2.04 D
1C	0.5	22.16	U	22.16 U
	1.0	11.56	D	
	1.0	11.64	D	5.80 D
1D	1.0	13.40	U	
	1.5	19.74	U	
	1.0	12.65	U	6.54 U
	1.0	7.48	D	
	1.5	11.32	D	3.76 D
1E	0.5	21.91	U	
	0.5	22.87	U	
	0.5	21.04	U	21.94 U
	1.0	11.84	D	
	1.0	12.72	D	
	1.0	12.59	D	6.20 D

1. The temperature was  $T = 0.822 \text{ m}\Omega = 28.8^\circ \text{ C}$ , which gives the viscosity of air  $= \eta = 1.867 \times 10^{-5} \text{ kg/m}\cdot\text{s}$ .
2. For this droplet,  $a = 4.9 \times 10^{-7} \text{ m} \pm 0.2 \times 10^{-7} \text{ m}$ .
3. The plate separation was  $0.767 \text{ cm}$  and the plate voltage was  $386 \text{ V}$ , which gives the electric field  $= E = 5.03 \times 10^4 \text{ V/m}$ .
4. The density of the oil was  $886 \text{ kg/m}^3$ , which gives the weight of the droplet  $= mg = 4.26 \times 10^{-15} \text{ N}$ .
5. The pressure was  $1.01 \times 10^5 \text{ Pa}$ .

### Table of Results

Drop# / Charge Letter	Charge for Going Up ( $\times 10^{-19} \text{ C}$ )	Charge for Going Down ( $\times 10^{-19} \text{ C}$ )	Average Charge ( $\times 10^{-19} \text{ C}$ )
1A	4.72	4.71	4.72
1B	6.18	6.35	6.27
1C	1.51	1.68	1.60
1D	3.09	3.06	3.08
1E	1.52	1.52	1.52

### Table of Final Analysis

Drop# / Charge Letter	Average Charge ( $\times 10^{-19} \text{ C}$ )	Differences between Letter Charges ( $\times 10^{-19} \text{ C}$ )	Number of e = Avg. Charge/Avg. Diff.
1E	1.52	D-E = 1.56	1 e
1C	1.60	D-C = 1.48	1 e
1D	3.08	A-D = 1.64	2 e
1A	4.72	B-A = 1.55	3 e
1B	6.27	Average diff. = 1.56	4 e

- The percent difference between the average difference between charges ( $1.56 \times 10^{-19} \text{ C}$ ) and the accepted value of  $e$  ( $1.60 \times 10^{-19} \text{ C}$ ) was 2.5 %.
- $a$  was  $4.9 \times 10^{-7} \text{ m} \pm 0.2 \times 10^{-7} \text{ m}$  (4 % error).
- Errors for  $q$  were 2 % (1A), 2 % (1B), 0 % (1C), 4 % (1D).

# ***Technical Support***

## **Feedback**

If you have any comments about the product or manual, please let us know. If you have any suggestions on alternate experiments or find a problem in the manual, please tell us. PASCO appreciates any customer feedback. Your input helps us evaluate and improve our product.

## **To Reach PASCO**

For technical support, call us at 1-800-772-8700 (toll-free within the U.S.) or (916) 786-3800.

fax: (916) 786-3292

e-mail: techsupp@PASCO.com

web: www.pasco.com

## **Contacting Technical Support**

Before you call the PASCO Technical Support staff, it would be helpful to prepare the following information:

- ▶ If your problem is computer/software related, note:
  - Title and revision date of software;
  - Type of computer (make, model, speed);
  - Type of external cables/peripherals.
- ▶ If your problem is with the PASCO apparatus, note:
  - Title and model number (usually listed on the label);
  - Approximate age of apparatus;
  - A detailed description of the problem/sequence of events. (In case you can't call PASCO right away, you won't lose valuable data.);
  - If possible, have the apparatus within reach when calling to facilitate description of individual parts.
- ▶ If your problem relates to the instruction manual, note:
  - Part number and revision (listed by month and year on the front cover);
  - Have the manual at hand to discuss your questions.