

Physics

Chemistry · Biology

Technology



Lehr- und Didaktiksysteme
LD Didactic GmbH
Leyboldstrasse 1 · D-50354 Huerth

04/07-W03-Hund

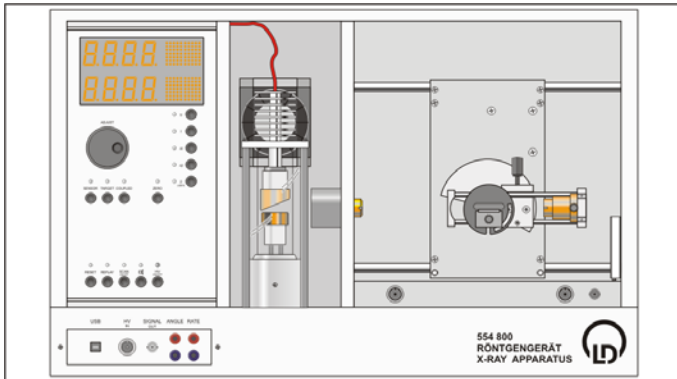

Instruction sheet 554 800

X-ray apparatus (554 800)

X-ray apparatus Mo, complete (554 801)

Radiation protection, administrative requirements

Before putting the X-ray apparatus into operation for the first time, it is your responsibility to notify all relevant authorities and obtain any permits required by the laws and regulations of your country.

The tube high voltage can only be switched on and X-rays generated when the safety circuits have been properly closed. Two mutually independent safety circuits secure the lead glass sliding doors. The maximum tube high voltage and maximum emission current are also monitored in a safety circuit.

Under the maximum operating conditions of $U = 37 \text{ kV}$ and $I = 1.2 \text{ mA}$, which cannot be exceeded, the local dose rate at a distance of 10 cm from touchable surfaces is less than $1 \mu\text{Sv/h}$.

The X-ray apparatus thus fulfills all regulations governing an X-ray apparatus and fully protected device for instructional use and is type approved for school use in Germany (BfS 05/07 V/Sch R6V).

Only the two lead glass sliding doors on the front of the X-ray apparatus may be opened. If the bottom or side plates are opened (impeded by safety screws), the type approval is void and the device may not be operated in Germany. The type approval is also void when the X-ray apparatus is repaired or manipulated in a manner not connected with the assembly of experiments in the laboratory. Repairs may only be carried out by the manufacturer, LD Didactic GmbH. The only exceptions to this are the replacement of the X-ray tube and any height adjustments of screws which are possible through holes in the bottom plate provided by the manufacturer for this purpose.

Depending on the legal requirements of your country, you may be required to maintain a history of your apparatus, analogous to the enclosed form.

Safety notes

The X-ray apparatus generates ionizing radiation which can exceed a local dose rate of 10 Sv/h in the X-ray tube's cone of radiation. This dose rate can damage living tissue even for short exposure times. The built-in protection and screening measures reduce the local dose rate outside of the X-ray apparatus to less than $1 \mu\text{Sv/h}$, a value which is on the order of magnitude of the natural background radiation. The high dose rate which is produced inside the device means that the operator must use special care when operating the X-ray apparatus.

The X-ray apparatus fulfills the safety requirements for electrical equipment for measurement, control and laboratory use according to DIN EN 61010 part 1 and is constructed so as to fulfill the requirements of protection class I. It is intended for operation in dry rooms which are suitable for electrical operating equipment or installations, height 0 - 2000 m above sea level. When used as intended the X-ray apparatus is safe to operate.

- Keep the X-ray apparatus secure from access by unauthorized persons.
- Before putting the device into operation for the first time, check the rating plate (on rear of housing) to make sure that the mains voltage value given there agrees with the mains voltage at your location
- Inspect the housing and the control and display elements of the X-ray apparatus, particularly the lead glass panes and sliding doors as well as the lead glass tube surrounding the X-ray tube, carefully for damage before putting the device into operation.
- Before putting into operation, make sure that the Anode cable is securely plugged into the heatsink of the anode.

If any faults or defects are noted, do not put the X-ray apparatus into operation. Notify your local LD Didactic GmbH representative immediately.

- Do not put live animals inside the X-ray apparatus.

Do not allow the anode of the X-ray tube to overheat:

- When putting the X-ray apparatus into operation, check to make sure that the ventilator in the tube chamber is turning.

Table of contents

1 Overview	3	10 Changing the fuse	11
2 Description	3	11 Operating and experimenting with the device	11
3 Scope of supply	4	a) Putting the X-ray apparatus into operation	11
a) X-ray apparatus (554 800)	4	b) Selecting the measuring parameters	11
b) X-ray apparatus, Mo, complete(554 801)	4	c) Manually positioning the goniometer arms	11
4 Technical data	4	d) Experiments with the fluorescent screen	12
5 Notes on putting into operation and transporting	5	e) "Exposure timer" mode	12
6 Testing the function of the safety circuits	5	f) "Auto-scan" mode	12
7 Components	5	g) "Manual scan" mode	12
a) Mains power panel	5	h) Bragg reflection at an NaCl crystal	12
b) Control panel:	5		
c) Connection panel	7		
d) Tube chamber	8		
e) Experiment chamber	8		
f) Fluorescent screen	9		
g) Free channel	9		
h) Lock	9		
i) Feet	9		
k) Carrying handles	9		
8 Recording and evaluating measurement data	10		
a) Rate measurements	10		
b) Data output during scanning	10		
c) Data readout after scanning	10		
d) Recording data with the software "X-ray apparatus"	10		
e) Recording data with alternative software	10		
9 Care and maintenance	11		
a) Storing the apparatus	11		
b) Cleaning	11		

1 Overview

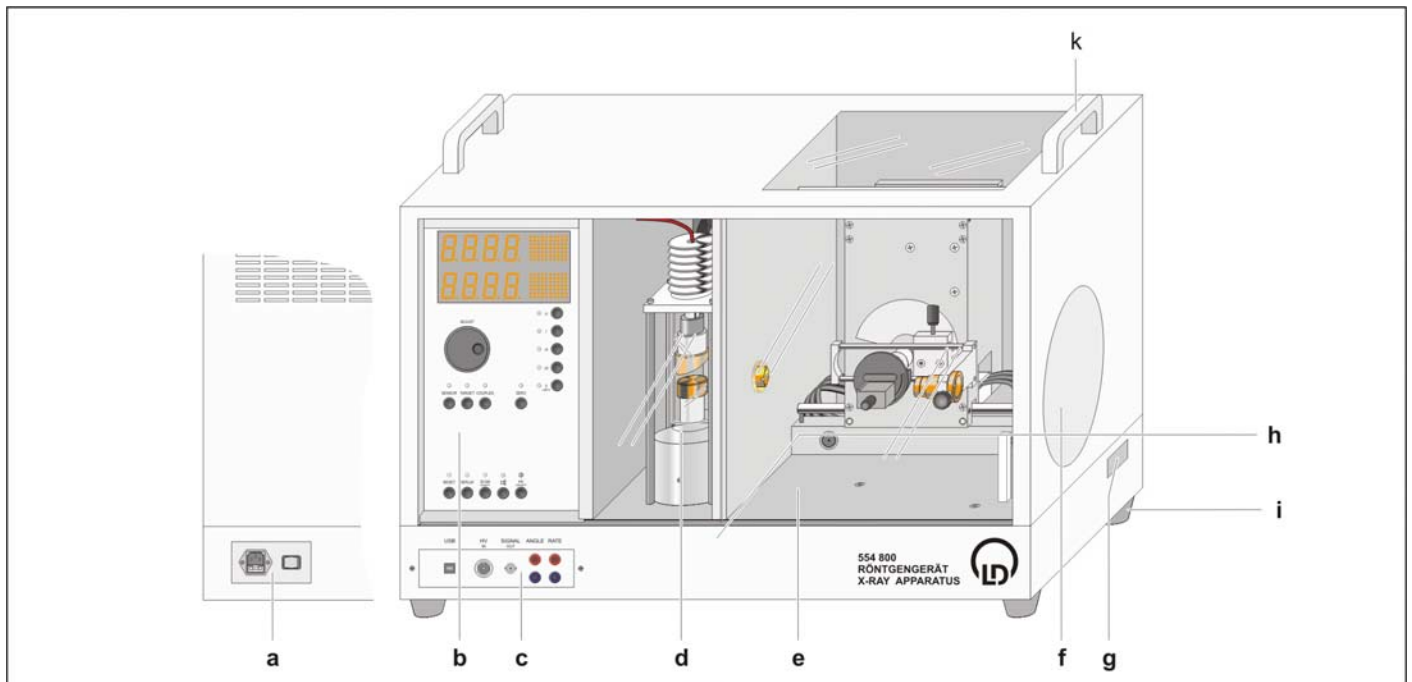

- | | | | |
|----------------------------|---|-----------------------------|---------------------------|
| a Mains power panel | d Tube chamber
(with X-ray tube Mo) | f Fluorescent screen | i Feet |
| b Control panel | e Experiment chamber (here
with goniometer) | g Free channel | k Carrying handles |
| c Connection panel | | h Lock | |

2 Description

The X-ray apparatus is a fully-featured, microprocessor-controlled device designed for conducting a wide variety of experiments in physics and related disciplines. Experiments at the boundary between physics and medicine include the transillumination of objects and observing them on a fluorescent screen or on an X-ray film, and experiments on ionization and dosimetry. In physics, the experiments range from atomic physics to solid-state physics.

You can set all parameters on the X-ray apparatus manually and read them from the digital display. The two arms of the two-circle goniometer (included with 554 801) can be controlled either individually or with 2:1 coupling, and either manually or automatically. Usually, the sensor on the sensor arm is a Geiger-Müller counter tube, while on the target arm a crystal, a scattering body or an absorber is pivoted or turned as the target. A rate meter for a Geiger-Müller counter tube (end-window counter) is also integrated. This means that you can use the X-ray apparatus as a stand-alone device, in conjunction with a computer via the built-in USB port or with an XY recorder connected.

It is possible to carry out the following experiments with the X-ray apparatus:

- Transillumination and X-ray photography
- Ionization and dosimetry
- Material-dependent and thickness-dependent attenuation of X-rays
- Continuum and characteristic lines, investigating the X-ray source
- Fine structure and shell model of the atom
- Energy-dependent absorption and K-edges
- Moseley's law and determining the Rydberg frequency
- Compton effect
- Duane-Hunt relation (determination of Planck's constant from the limit wavelength)
- Bragg reflection for determining the lattice plane spacing of various crystals
- Investigating crystal structures by means of Laue diagrams and Debye-Scherrer photographs
- X-ray diffraction analysis at polycrystalline metal foils and powder samples, texture
- X-ray spectroscopy with the X-ray energy detector (559 938)

3 Scope of supply

a) X-ray apparatus (554 800)

- 1 Basic X-ray apparatus
- 2 Quality certificates for X-ray apparatus /*/
- 2 Copies of type approval /*/
- 1 Instruction sheet 554 800
- 1 CD-ROM "X-ray Apparatus"
- 1 USB cable
- 1 Collimator
- 1 Protective plate
- 1 Dust cover

b) X-ray apparatus, Mo, complete (554 801)

- 1 Basic X-ray apparatus
- 1 X-ray tube Mo (554 861)
- 1 Goniometer (554 831)
- 1 NaCl monocrystal (554 78)
- 2 Quality certificates for X-ray tube and apparatus /*/
- 2 Copies of type approval /*/
- 1 Instruction sheet 554 800
- 1 Instruction sheet 554 861
- 1 Instruction sheet 554 831
- 1 CD-ROM "X-ray Apparatus"
- 1 USB cable
- 1 Collimator
- 1 Zirconium filter
- 1 Protective plate
- 1 Dust cover

/*/ Required for registration in Germany

4 Technical data

School X-ray apparatus with full protection, type-approved for use in Germany (BfS 05/07 V/Sch RöV, permitting the use of changeable tubes Fe, Cu, Mo, Ag, W)

Dose rate in 10 cm distance: < 1 μ Sv/h

Doors, high voltage and tube current each supervised by two independent and monitored security circuits (as required by the German PTB for design test, 2005)

Tube high voltage: 0.0 ... 35.0 kV (stabilized DC voltage)

Tube current: 0.0 ... 1.0 mA (independently regulated DC current)

Visible X-ray tube with molybdenum anode:
 $K_{\alpha} = 17.4$ keV (71.1 pm), $K_{\beta} = 19.6$ keV (63.1 pm)

Fluorescent screen for transillumination experiments:
 D = 15 cm

Built-in rate meter:

maximum internal counting rate: 65,535 /s
 maximum displayable counting rate: 9999 /s
 voltage supply for Geiger-Müller counter tube: 500 V fixed
 gate time for rate meter: 0.1 ... 9999 s

Loudspeaker: user controlled for acoustic control of the count rate

Two 4-digit displays (25 mm high) for
 tube high voltage, anode current, counting rate,
 sensor and target angle, scanning range, angular step width
 or measuring time per angular step

Goniometer (554 831) with stepping motors
 manual adjustment and automatic Goniometer scan
 (sensor or target alone, 2:1 coupling),
 range: Target without limit (0.360°), Sensor -10 .. +170°
 step size 0.1°

Exposure timer, Gate time 0.5 s – 9999 s

Lead-throughs into the experiment chamber:

high-voltage coaxial cable
 BNC-coaxial cable
 free channel for tubing, cable etc.

Outputs:

Analogue output ANGLE proportional to scanning angle with
 5 V / max. scanning angle for $\beta \geq 0^\circ$ (accuracy: $\pm 3\%$)
 Analogue output RATE proportional to counting rate with 5 V
 / 10000 /s for $\beta \geq 0^\circ$ (accuracy: $\pm 3\%$)

USB port for data transmission to computer and for controlling the experiment

LabView™ drivers for Windows and Linux available for
 download at <http://www.ld-didactic.com> to realize your own
 measurements or controls

Mains voltage: see rating plate on rear of housing

Power consumption: 120 VA

Protection: see fuse rating on rear of housing

Dimensions: 67 cm × 48 cm × 35 cm

Weight: 41 kg

LabView™ is a trademark of National Instruments

5 Notes on putting into operation and transporting

Users must exercise special care where the X-ray apparatus is concerned:

- Immediately after unpacking the X-ray apparatus, inspect it for transportation damage and check to make sure that the delivery is complete (see section 3).

If the X-ray apparatus appears to be damaged in spite of the special packing, do not put the apparatus into operation ! Notify your local LD Didactic GmbH representative immediately.

Only transport the X-ray apparatus in its special packing and on a pallet.:

- We recommend that you retain the original packing for this purpose.
- Dismantle the collimator and pack it in separate packing for the shipment.
- Screw the goniometer tight if necessary.

6 Testing the function of the safety circuits

According to test design requirements (PTB 2005), the x-ray machine itself has to verify before every activation of the high voltage that the security circuits are functional.

This check will be performed automatically when the doors are closed and either the HV ON/OFF or SCAN ON/OFF button is pressed. During this check the x-ray machine displays the text "SAFE" and after successfully finishing the test an additional "OK".

When one of the doors is open, the self-test will fail and no high voltage can be activated, the upper line of the display field is blinking.

7 Components

a) Mains power panel:

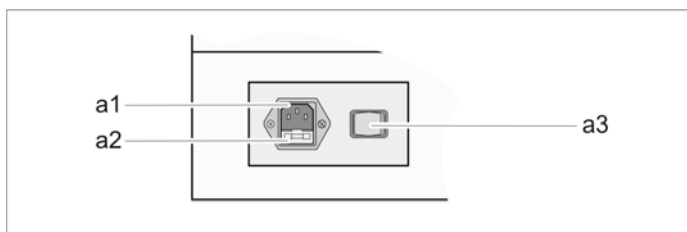

- a1 Appliance connector
- a2 Fuse holder
- a3 Mains power switch

b) Control panel:

The X-ray apparatus is controlled using a number of keys to set the parameters and select the operating mode, a knob for setting the desired value of the selected parameter and a display panel which shows the set value. For each pushbutton, an LED indicates the corresponding parameter selection.

Depending on the respective state of the X-ray apparatus it is not possible to actuate all keys at all times. In particular, some keys have no function when the goniometer (554 831) is not mounted.

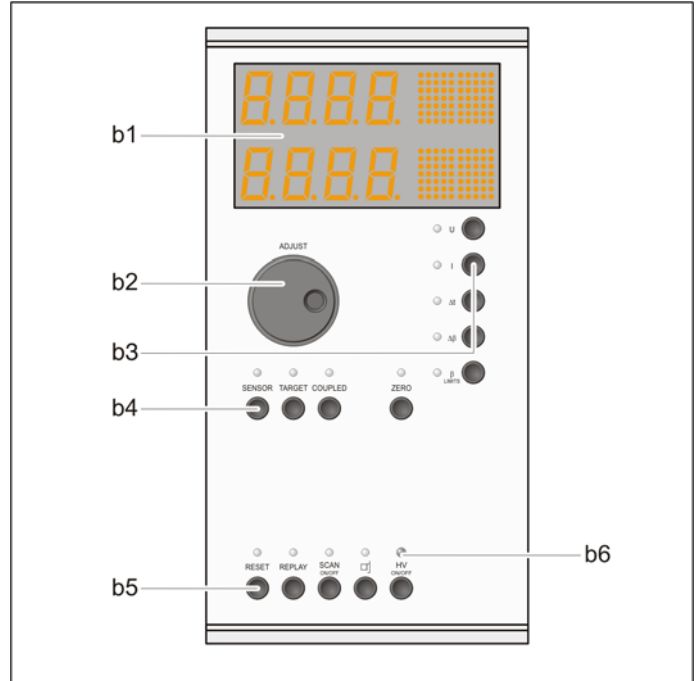

- b1 Display field
- b2 Knob
- b3 Parameter selector keys
- b4 Scan-mode keys
- b5 Operational keys
- b6 High-voltage indicator lamp

b1) Display panel:

Top display field:

shows the current counting rate (number height: 25 mm, unit of measure: LED dot matrix)

Bottom display field:

shows the quantity selected using a key (number height: 25 mm, unit of measure: LED dot matrix)

In "coupled" scanning mode, the angular position of the target appears in the bottom display field; the top display field can be toggled between the counting rate and the angular position of the sensor by pressing the COUPLED key.

b2) ADJUST knob:

enables you to set the desired values.

This incremental control element can be turned in both directions and has a dynamic response, i.e. the values change by greater increments when the knob is turned rapidly. The apparatus accepts the displayed values when a key is pressed.

b3) Parameter selector keys:

Key U:

activates display and setting of the tube high voltage U .

Value range: 0.0-35.0 kV

Step width: 0.1 kV

Default: 5.0 kV

The set value is displayed regardless of whether the tube high voltage is switched on (see keys SCAN ON/OFF and HV ON/OFF).

Key I:

activates display and setting of the emission current I .

Value range: 0.00-1.00 mA

Step width: 0.01 mA

Default: 0.00 mA

The set value is displayed regardless of whether the emission current is flowing.

Key Δt :

activates display and setting of the measuring time (per angular step) Δt .

Value range: 1-9999 s

Step width: 1 s

Default: 1 s

Key $\Delta\beta$:

when the goniometer (554 831) is mounted, this activates the display and setting of the angular step width $\Delta\beta$ for auto-scan mode.

Value range: 0.0°-20.0°

Step width: 0.1°

Default: 0.1°

The setting $\Delta\beta = 0.0^\circ$ deactivates auto-scan mode and activates "exposure-timer" mode.

Key β LIMITS:

when the goniometer (554 831) is mounted, this activates the display and definition of the upper and lower limit angles for auto-scan mode. A measurement cannot be started when the upper limit is less than the lower limit. The display flashes until this situation is corrected.

The first time this key is pressed, the display panel shows the symbol \downarrow . You can now set the lower limit angle.

The second time this key is pressed, the display panel shows the symbol \uparrow . You can now set the upper limit angle.

The symbol \circ in the display panel indicates the setting $\Delta\beta = 0.0^\circ$. Auto-scan mode is deactivated.

b4) Scanning-mode keys:

Key SENSOR:

when the goniometer (554 831) is mounted, this key activates "sensor" scanning in auto-scan or manual scan modes.

You can define the limit angles of the sensor arm for auto-scan. Sensor arm movement can be controlled manually or automatically. The bottom display field shows the angular position of the sensor.

Key TARGET:

when the goniometer (554 831) is mounted, this key activates "target" scanning in auto-scan or manual scan modes.

You can define the limit angles of the target arm for auto-scan. Target arm movement can be controlled manually or automatically. The bottom display field shows the angular position of the target.

Key COUPLED:

when the goniometer (554 831) is mounted, this key activates "coupled" scanning in auto-scan or manual scan modes. You can define the limit angles of the target arm for auto-scan.

The sensor and target arms can be moved manually or automatically with an angular coupling of 2:1. In manually controlled movement, the reference point for the 2:1 coupling is the angular position of the target and the sensor before the COUPLED key is pressed, and for automatic movement the reference point is the zero point of the measuring system.

The bottom display field shows the angular position of the target. Pressing the COUPLED key toggles the upper display field between the counting rate and the angular position of the sensor.

Key ZERO:

when the goniometer (554 831) is mounted, this key causes the target and sensor arms to move to the zero position of the measuring system (see instruction sheet of the goniometer).

b5) Operational keys:**Key RESET:**

when the goniometer (554 831) is mounted, this key causes the target and sensor arms to move to the zero position of the measuring system and resets all parameters to the default settings.

The tube high voltage is switched off.

Key REPLAY:

activates readout of the stored measured values.

The angular positions set manually using the ADJUST knob and the respectively corresponding counting rates averaged over the measuring time Δt are displayed in the display field and output via the USB port. The corresponding voltages are output at the sockets labeled ANGLE and RATE.

When the goniometer (554 831) is mounted, the position of the goniometer arms remains unchanged.

You can access the measured values as often as you like, as long as the RESET or SCAN keys are not pressed and the X-ray apparatus is not switched off.

Key SCAN ON/OFF:

Starts a self-test of the security circuits, if successful then switches the tube high voltage on and activates the measuring program (provided that the doors are closed).

This key can for $\Delta\beta > 0.0^\circ$ (auto-scan mode) only be actuated with defined goniometer (key functions SENSOR, TARGET or COUPLED) or for $\Delta\beta = 0.0^\circ$ (exposure-timer mode).

In auto-scan mode, the device first travels to the zero position of the measuring system and then to the lower limit angle. The tube voltage is then switched on. The scan starts as soon as the tube high voltage is present and an emission current is flowing. The starting and end points are the upper and lower limit angles set with β LIMITS.

In "exposure timer" mode, the tube high voltage is switched on. Once the tube high voltage is present and the emission current is flowing, the stopclock counts backward to indicate the remaining exposure time.

Key \square :

toggles the acoustic pulse indicator for the sensor on and off.

Key HV ON/OFF:

Starts a self-test of the security circuits, if successful then switches the tube voltage on (possible only with doors closed).

b6) High voltage indicator lamp:

flashes when the tube high voltage is switched on.

The tube high voltage can be switched on using either the SCAN or HV ON/OFF key.

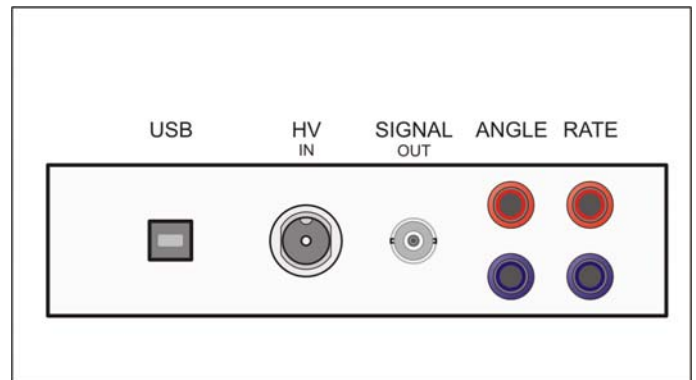
c) Connection panel:**USB output:**

The interface is electrically (optoelectronically) isolated from the X-ray apparatus. The apparatus is connected to a computer via the supplied cable.

Input HV IN:

High voltage input, connected with high voltage output HV OUT in the terminal bracket of the experiment chamber.

The high voltage input enables e.g. experiments with a Geiger-Müller counter tube connected to an external counter.

Output SIGNAL OUT:

BNC output, connected with the BNC input SIGNAL IN of the terminal bracket of the experiment chamber.

BNC output enables e.g. experiments using sensors with BNC connector.

Output ANGLE:

Analog output for connecting an XY-recorder.

When the SCAN or REPLAY key is pressed, an angle-proportional voltage of $5 \text{ V} / \text{max. scanning angle}$ is output for the target arm of the goniometer.

Output RATE:

Analog output for connecting an XY-recorder.

When the SCAN or REPLAY key is pressed, a voltage proportional to the counting rate is output with an amplitude of $0.5 \text{ V} / 1000 / \text{s}$.

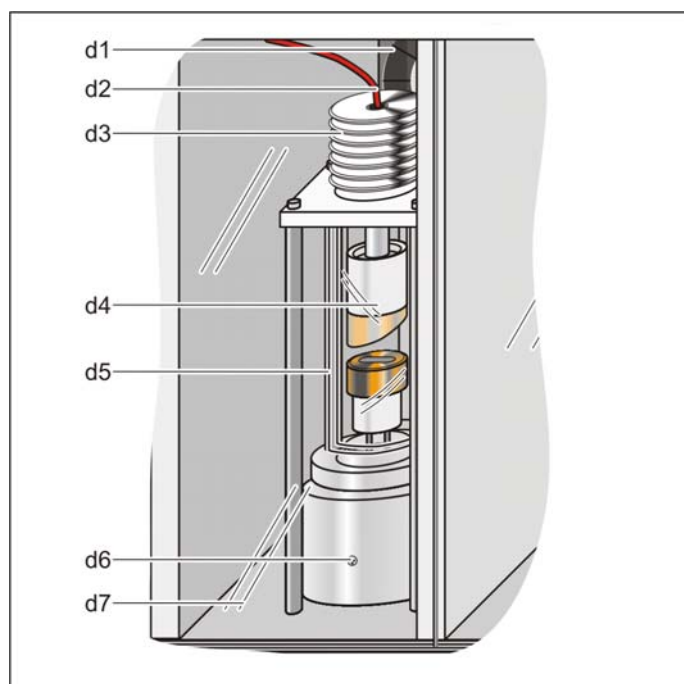
d) Tube chamber:

- d1 Ventilator
- d2 High-voltage cable
- d3 Heat sink
- d4 X-ray tube
- d5 Lead glass tube
- d6 Tube socket with clamping screw
- d7 Lead glass sliding door

The tube chamber accommodates the X-ray tube and serves as shielding for the X-ray tube.

Also during operation the X-ray tube is visible through the lead glass sliding door and the lead glass tube which surrounds the X-ray tube. This makes it possible e.g. to observe the change in the cathode temperature when the cathode current is varied.

Mounting and demounting the X-ray tube:

Do not remove the lead glass tube from the tube chamber. The mounting screws of the tube are compound-filled to prevent this.

- Never loosen the mounting screws.

The x-ray tubes are completely aligned and can be easily interchanged without re-adjustment.

See the instruction sheets for the x-ray tube Mo (554 861), x-ray tube Cu (554 862), x-ray tube Fe (554 863), x-ray tube W (554 864), x-ray tube Ag (554 865),

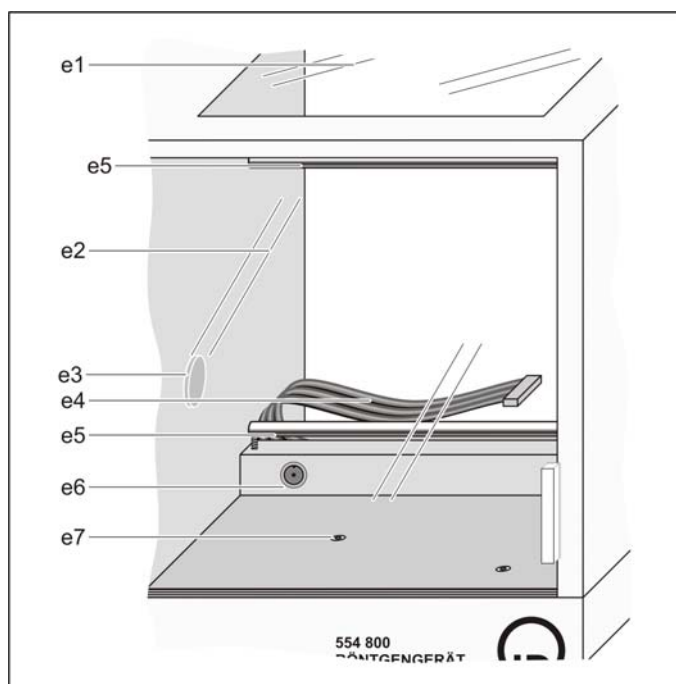
e) Experiment chamber:

- e1 Lead glass window
- e2 Lead glass sliding door
- e3 Collimator mount
- e4 Ribbon cable with connector
- e5 Guide rails
- e6 Terminal bracket
- e7 Mounting sockets

The experiment chamber is designed to accommodate experiment equipment such as the goniometer (554 831), the film holder X-ray (554 838) or the plate capacitor X-ray (554 840), which all fit the mounting sockets.

The experiment equipment can be observed during the experiment directly through the lead glass sliding door in front of the experiment chamber and the lead glass pane above it.

Terminal bracket:

Input GM TUBE INTERNAL RATE METER:

coaxial socket for connecting an end-window counter (559 01).

Output HV OUT:

high-voltage output, connected with the high-voltage input HV IN in the connection panel.

The high voltage output enables e.g. experiments with a Geiger-Müller counter tube connected to an external counter.

Input SIGNAL IN:

BNC input, connected with the BNC output SIGNAL OUT on the connection panel.

The BNC input enables e.g. experiments using sensors with BNC connector.

Mounting the goniometer:

see instruction sheet of the goniometer (554 831).

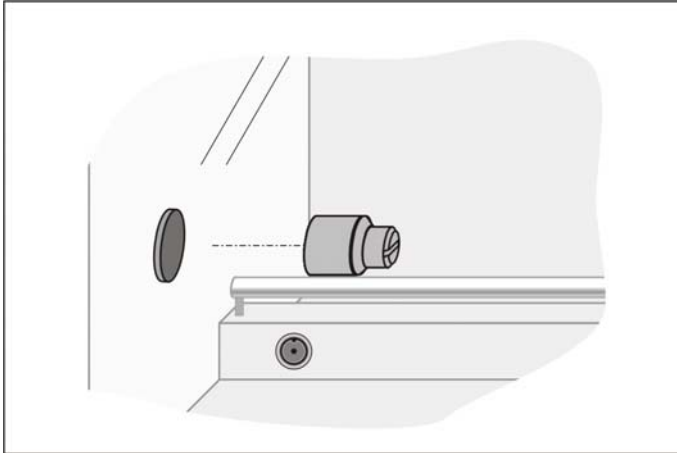
Mounting the collimator:

- Turn the collimator so that the spring bushings are aligned vertically and the collimator slit is horizontal.
- Slide in the collimator in until the bushings are connected to the pins of the collimator seat.

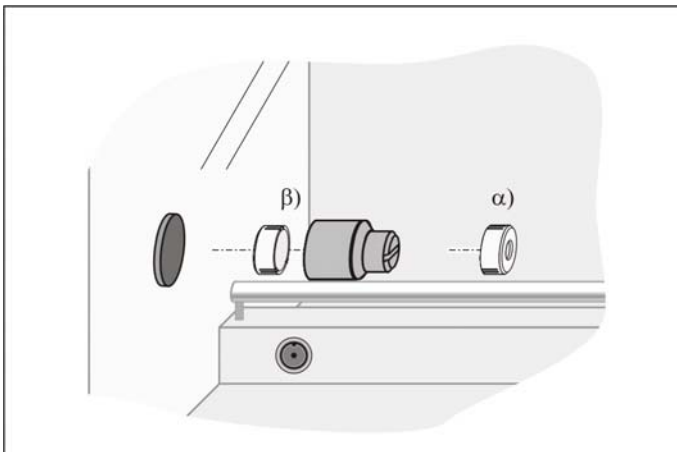
Attaching the zirconium filter:

α) In most cases:

- plug the zirconium filter onto the collimator

β) When using the Compton accessory X-ray (554 836):

- Demount the collimator.
- Place the zirconium filter on the front end of the collimator.
- Remount the collimator together with the zirconium filter.
- The collimator will protrude a bit more than before.

f) Fluorescent screen:

The fluorescent screen is a lead glass pane that is coated with a fluorescent material, and forms a radiation-tight seal of the experiment chamber; it serves as a simple proof of X-rays, e.g. in transillumination experiments using objects with different absorption characteristics. The "direct observation" of the incident X-rays is made possible through stimulation of luminescence phenomena. The diameter has been dimensioned so that the fluorescent screen is fully illuminated when the collimator is de-mounted.

Always be sure to attach the enclosed cover to the fluorescent screen to protect the fluorescent layer from ambient light.

g) Free channel:

The free channel is a conduit between the experiment chamber and the outside of the housing. In terms of radiation protection technology it is designed as a labyrinth, so that the experiment chamber can remain accessible even when the lead glass sliding door is closed and the X-ray tube is switched on.

The rectangular cross-section of the free channel (60 mm \times 20 mm) allows you to lay e.g. a cable with 25-pin sub-D plug or a pump hose for evacuating an ionization chamber.

h) Lock:

the doors are locked automatically and re-opened only when no x-ray radiation can be produced.

i) Feet:

Once it is unpacked from the original transport packing, the X-ray apparatus must always be set up on so that it rests only on its feet.

k) Carrying handles:

When not in its original packing, the X-ray apparatus can only be transported by its carrying handles.

8 Recording and evaluating measurement data

a) Rate measurements:

The X-ray apparatus internally generates a high voltage for a Geiger-Müller counter tube (end-window counter), counts its pulses continuously and displays these in the display panel every second as the counting rate 1/s (independently of the set measuring time Δt). When no counter tube is connected, the display reads 0.

Pressing the SCAN key causes the device to store all measured counting rates in the internal memory.

b) Data output during scanning:

The angular position of the goniometer arm set in scan mode and the counting rate are shown in the display panel of the X-ray apparatus. The angular reading is updated for each new angular position of the goniometer arm and the counting rate is updated every second.

The output sockets ANGLE and RATE output voltages proportional to the angle and the counting rate respectively to permit the use of a chart recorder. The voltages change on each expiration of the set measuring time Δt per angular step. The voltage at the RATE output corresponds to the mean value of the counting rate over the measuring time Δt .

c) Data readout after scanning:

Once a scan is completed, you can display the entire contents of the measured-value storage using the REPLAY key. You can do this by using the ADJUST knob to manually set all angular positions of the goniometer arm set in scan mode.

The display panel shows the angular position and the counting rates averaged over the measuring time Δt per angular step. Proportional voltages are output via the output sockets ANGLE and RATE.

d) Recording data with the software "X-ray apparatus":

You can display and evaluate the data stream via the USB port using the software "X-ray apparatus" supplied with the device. To install the software, you need a computer on which Windows 98/2000/XP/Vista is properly installed. The program contains detailed help on the use of all functions, as well as numerous useful hints and experiment notes. You can access this help with F1 after starting the program, and print it out if desired.

The program SETUP.EXE on the enclosed CD-ROM prompts you to specify the preferred user-interface language and installation directory, and then installs the software automatically. After installation is complete, the software can be found in the "Start" menu under "Programs" → "X-ray Apparatus". You can uninstall the software at any time using the Software icon in the Control Panel. All future software updates (enhancements, patches) will be made available as they appear free of charge on our website <http://www.ld-didactic.com>.

After starting the software, press F5 ("Settings" → "General") to change the serial interface. You can also use this tab to change the language of the user interface at any time.

If the error message "X-ray apparatus not found" appears when the software starts, this may be due to one of the following reasons:

- the X-ray apparatus is switched off.
- the cable between the X-ray apparatus and the computer is not properly connected.
- the wrong serial interface has been defined.
- the REPLAY key is pressed.

e) Recording data with alternative software:

All usual programming languages can access the x-ray apparatus via XRayAPI.DLL (Windows) or libxrayapi.so (Linux). For this XRayAPI.DLL or libxrayapi.so has to be included and called. The necessary declarations for C/C++ are contained in XRayAPI.H. All three files are also contained in our free Developer Information from the Internet (<http://www.ld-didactic.com>).

Our LabVIEW™ driver for the x-ray apparatus is also free available on the Internet. In addition to the VIs (Virtual Instruments) for driving the x-ray apparatus, the driver also contains application examples.

LabVIEW™ is a trademark of National Instruments.

9 Care and maintenance

a) Storing the apparatus:

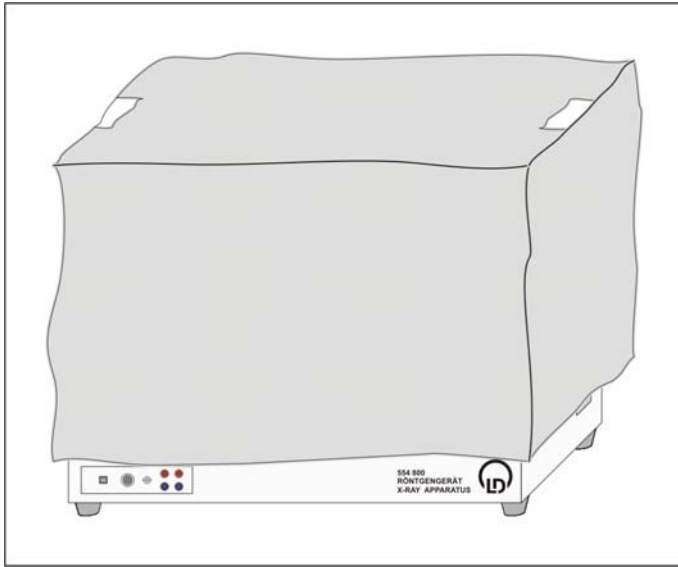

- Always attach the cover to protect the luminescent coating of the fluorescent screen from ambient light.
- Always cover the X-ray apparatus with the enclosed dust cover when storing for longer periods.

b) Cleaning:

- Clean all glass surfaces of the X-ray apparatus using only a mild glass cleaner (lead glass is very soft and sensitive to scratching).
- Do not clean the enameled surfaces of the X-ray apparatus with aggressive cleaning agents.

10 Changing the fuse

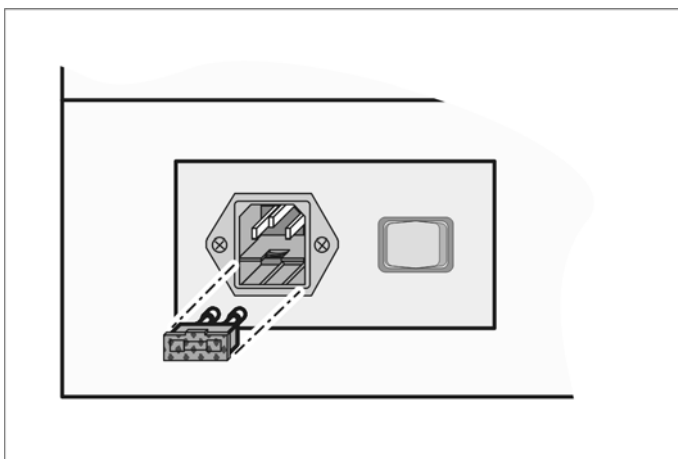

- Pry out the fuse holder.
- Check the reserve fuse for the correct rating (see technical data) and replace the defective fuse with the reserve fuse.
- Reinsert the fuse holder.

11 Operating and experimenting with the device

a) Putting the X-ray apparatus into operation:

- Connect the X-ray apparatus to the mains and switch it on.
- Press the key U.
- Use the ADJUST knob to set e.g. $U=20$ kV:
The display panel shows the set value.
- Press the key I
- Use the ADJUST knob to set e.g. $I=1.00$ mA:
The display panel shows the set value.
- Check to make sure that the lead glass sliding doors are properly closed, then press the HV ON/OFF key:
The high voltage indicator starts flashing and the hot cathode of the X-ray tube becomes luminous. The system is now generating X-rays.
- Press the key I and use the ADJUST knob to vary the emission current I .
The brightness of the hot cathode changes.

b) Selecting the measuring parameters:

- Press key U, I, Δt , $\Delta\beta$ or β LIMITS.
- Set the desired value with the ADJUST knob.
The set value appears in the display field.
- Press any key to terminate parameter setup.

c) Manually positioning the goniometer arms:

The goniometer is positioned solely by means of electric stepper motors:

- Do not block the target arm and sensor arm of the goniometer and do not use force to move them.

Either:

- Press SENSOR or TARGET.
- Set the desired value with the ADJUST knob.
The set value appears in the display panel, the sensor or target arm moves to the desired angular position.

or:

- Press the key COUPLED.
- Set the desired target value with the ADJUST knob.
The set value appears in the display panel, the target arm moves to the desired angular position and the sensor arm automatically moves with twice the set angular step width.

Note: "Sensor angle = $2 \times$ target angle" is only true when the setup was previously set to the zero position of the measuring system with the ZERO key or in the auto-scan mode.

d) Experiments with the fluorescent screen:

Experiments with the fluorescent screen provide an introduction to the linear propagation of x-rays. In addition, it is possible to observe the effect of the parameters emission current and tube high voltage on the brightness and contrast of the screen image.

- Carry out all experiments in a darkened room.
- Remove the protective cover from the fluorescent screen and demount the collimator.
- To obtain a sharp image, place the object to be transilluminated directly in front of the fluorescent screen; place the object in the ray path at a distance from the fluorescent screen to obtain an enlarged image.
- Close the lead glass sliding door of the X-ray apparatus.
- Set the desired values for the measuring parameters I and U and switch on the tube high voltage using the HV ON/OFF key.
- Vary the measuring parameters I and U .
- Replace the protective cover plate when the experiment is finished.

e) "Exposure timer" mode:

As the name implies, "exposure timer mode" lets you set e.g. the exposure times for X-ray films or the measuring time for measurements of individual counting rates.

- Mount the desired accessories (e.g. goniometer and sensor or film holder X-ray).
- Steer the sensor or target arm of the goniometer into position manually as necessary using the ADJUST knob.
- Vary the measuring parameters I and U .
- Set the angular step width $\Delta\beta = 0.0^\circ$.
- Set the desired measuring time Δt .
- Start the measurement with the SCAN key:
The measuring time remaining counts down to zero on the display panel. The target and sensor arms remain in the selected position.
- When the measuring time expires, press the REPLAY key.
The display panel shows the counting rate averaged over the measuring time Δt .

f) Auto-scan mode:

In auto-scan mode, the goniometer arms move automatically when the SCAN key is pressed. You can choose between the scan modes "Target", "Sensor" or "Coupled".

During the scan the apparatus displays the current counting rate and the target position, or alternatively the sensor and target positions in coupled scanning mode (see COUPLED key). The X-ray apparatus additionally stores all measured values (angles and counting rates).

- To select scan mode, press TARGET, SENSOR or COUPLED.
- Press the β -LIMITS key and set the lower scan limit using the ADJUST knob.
- Press the β -LIMITS key again and set the upper scan limit using the ADJUST knob.
- Select the measuring parameters I and U .
- Select the angular step $\Delta\beta$.

- Set the desired measuring time per angular step Δt .
- If desired, connect a computer via the USB port and start the program "X-ray apparatus".
- Start the automatic scan with the SCAN key.
- If desired, press REPLAY and browse through the stored measurement data for each angular step using the ADJUST knob.

g) Manual scan mode:

In manual scan mode, the goniometer arms are positioned manually using the ADJUST knob. You can choose between the scan modes "Target", "Sensor" or "Coupled".

- To select scan mode, press key TARGET, SENSOR or COUPLED.
- Select the measuring parameters I and U .
- Set the measuring time per angular step $\Delta t = 1$.
- Where appropriate, connect a computer via the USB port and start the program "X-ray apparatus".
- Steer the goniometer arm into the desired position manually using the ADJUST knob.
- Wait for about two seconds until the counting rate for the new angular position appears in the display panel, then note the counting rate.

Note: For lower counting rates, such as occur in Bragg reflection for higher diffraction orders, an exposure timer can be activated for each angular position to enable more precise determination of counting rates. In this case, you need to press the REPLAY key after expiration of the measuring time for each angular position in order to display the counting rate. However, this procedure is time-consuming.

h) Bragg reflection at an NaCl crystal:

- Mount the collimator.
- Mount the goniometer (554 831) completely.
- Mount the end-window counter (559 01) as the sensor.
- Mount the NaCl crystal for Bragg reflection (554 78) as the target.
- Restore the setup to the zero position of the measuring system.
- Select the measuring parameters U , I , Δt and $\Delta\beta$:
(e.g. $U = 35.0$ kV, $I = 1.0$ mA, $\Delta t = 10$ s and $\Delta\beta = 0.1^\circ$).
- Press the key COUPLED.
- Set the upper and lower target limit angles to the desired values (e.g. 2.5° and 30°).
- Connect the X-ray apparatus to a computer via the USB port and start the software "X-ray Apparatus".
- Press SCAN to start recording.